



MAGNAFLOW

Exhaust
PRODUCTS



• QUALITY • POWER • SOUND •

2012
Performance
CATALOG

ABOUT MAGNAFLOW

MagnaFlow Exhaust Products got its start as a natural extension of Car Sound Exhaust Systems, Inc., parent company, which specializes in superior catalytic converter technology. Car Sound Exhaust Systems, Inc., has spent 30 years earning a reputation as a market leader around the world.

Today, we at MagnaFlow Exhaust Products are extremely proud of this and stake our 30 years of experience and reputation on each and every one of our products. Each new product we develop is personally evaluated and tested by our team of designers and engineers, then field tested to ensure that these products meet our stringent quality and performance standards.

QUICK REFERENCE GUIDE

Performance Exhaust Systems

Car Applications.....	12
Truck Applications.....	28

Universal Exhaust Components

Hangers & Clamps.....	58
Smooth Transitions.....	58
Transition Pipes.....	59

Universal Mufflers & Tips

Oval Bodies.....	48
Round Bodies.....	50

Specialty & Race.....	51
Universal Mufflers With Tips.....	53
Tips.....	56

ABBREVIATIONS

A/T = Automatic Transmission
M/T = Manual Transmission
Incl = Including
Excl = Excluding
D/S = Driver Side
P/S = Passenger Side
Assy = Assembly
Eng = Engine
Bbl = Barrel
Cid = Cubic Inch Displacement
W/ = With
W/O = With Out
Conv = Converter
Dr = Door

DRW = Dual Rear Wheel
SRW = Single Rear Wheel
E.F.I. = Electronic Fuel Injection
DOHC = Dual Over Head Cam
SOHC = Single Over Head Cam
H.O. = High Output
WB = Wheel Base
2WD = 2 Wheel Drive
4WD = 4 Wheel Drive
FWD = Front Wheel Drive
AWD = All Wheel Drive
Cont. = Continued
EXT = Extended
STD = Standard

MARIO ANDRETTI
Racing Legend



TABLE OF CONTENTS

Cars

Acura.....	14
Audi.....	14
BMW.....	14
Buick.....	16
Cadillac.....	16
Chevrolet.....	17
Chrysler.....	19
Dodge.....	19
Eagle.....	20
Fiat.....	20
Ford.....	20
Honda.....	21
Hyundai.....	22
Infiniti.....	22
Kia.....	22
Lexus.....	22
Lincoln.....	22
Maserati.....	22
Mazda.....	22
Mercury.....	23
Mini.....	23
Mitsubishi.....	23
Nissan.....	23
Oldsmobile.....	23
Plymouth.....	24
Pontiac.....	24
Saturn.....	25
Scion.....	25
Subaru.....	25
Toyota.....	25
Volkswagen.....	25
Volvo.....	26

Trucks

AM General.....	30
Audi.....	30
Cadillac.....	30
Chevrolet.....	30
Chrysler.....	34
Dodge.....	34
Ford.....	36
GMC.....	39
Honda.....	42
Hummer.....	42
Infiniti.....	42
Isuzu.....	42
Jeep.....	43
Land Rover.....	44
Lincoln.....	44
Mazda.....	44
Mercury.....	44
Mitsubishi.....	45
Nissan.....	45
Saturn.....	45
Toyota.....	45

Universal Mufflers

3.5" x 7" Oval.....	48
4" x 9" Oval.....	48
5" x 8" Oval.....	48
5" x 11" Oval.....	49
4" Round.....	50
5" Round.....	50
6" Round.....	50
7" Round.....	50
7" Round Diesel.....	50
GlassPack.....	52

Race/Specialty Mufflers

4" Round.....	51
5" x 8" Oval.....	51
6" Round.....	51

Universal Mufflers with Tips

5" x 8" Oval.....	53
4" Round.....	53
5" Round.....	54
6" Round.....	54
7" Round.....	54
True Clamp-On Tips.....	56
Stainless Steel Tips.....	56
Hangers & Clamps.....	58
Smooth Transitions.....	58
Transition Pipes.....	59
Universal Ball Flanges.....	59
Custom Builder Kits.....	60
X-Pipe Kits.....	61



HEADQUARTERS

The MagnaFlow headquarters is a 50,000-square-foot office and special projects manufacturing facility. Home to Management, Sales, Marketing and state-of-the-art computer technology that links the various MagnaFlow production facilities.



RESEARCH & DEVELOPMENT

The 30,000-square-foot R&D Tech Center is home to the CAD Engineering Department, the Prototype & Fixturing Departments, two in-ground dynamometers, flow-bench testing, and sound testing.



MANUFACTURING & DISTRIBUTION

OCEANSIDE FACILITY

MagnaFlow's new 280,000 square-foot manufacturing and distribution facility is home to the latest robotics and automation technology. As the primary manufacturing facility, MagnaFlow's performance and emissions product lines take their initial form here. A sophisticated inventory and distribution system ensures timely delivery.



RANCHO SANTA MARGARITA FACILITY

MagnaFlow's secondary manufacturing center is 125,000 square-foot housing all operations required for the supplementary manufacturing of MagnaFlow mufflers, systems, tips and converters.



Compare MagnaFlow's Performance Exhaust components with any other manufacturer's and you will immediately see the difference in quality. MagnaFlow products are CAD designed and race proven under the world's most demanding real world applications. The Stainless Steel construction, use of Mandrel bent tubing and Straight-Through Design is why MagnaFlow confidently provides a Lifetime Warranty and it is how MagnaFlow delivers unparalleled Quality, Power, and Sound.

Body filled with high temperature acoustical suppression material for maximum sound absorption.

Heavy gauge stainless steel body, end caps and one piece core deliver long life protection.

Large diameter, perforated stainless steel core eliminates flow restrictions of louvered-style core.





AXLE-BACK EXHAUST SYSTEM

Exhaust system built to fit to the factory exhaust at our rear axle. These systems are 100% emissions compliant and designed to enhance power while providing similar siatics appeal .



CAT-BACK EXHAUST SYSTEM

Exhaust system built to fit-behind the factory catalytic converters. These systems are 100% emissions compliant and designed to optimize exhaust flow using mandrel bent tubing and straight through mufflers.



PERFORMANCE PIPES

Mandrel bent exhaust inlet pipes with or without converters designed for enhanced performance. Check with local lane for use of my off road products.

Stainless steel mesh provides durability under high temperature, with additional sound absorption and no blow-out.

All welded, lap jointed contacts avoid distortion and cracking at joints.

STREET/TOURING SERIES

Exhaust systems are designed for those seeking increased performance and better economy, balanced with interior and exterior noise levels. These systems are tested against SAE j1169 standards.

COMPETITION/SPORT SERIES

Exhaust systems are designed for those seeking maximum performance, reduced mass and an aggressive exhaust note that demands attention. These systems may not comply with all local or federal noise requirements.



FEATURES

- Lifetime Warranty
- Stainless Steel Construction
- Hassle Free, Bolt-On Installation
- High Flow Straight Through Design
- Turn-Down Before the Axle Configuration





FEATURES

- Dyno Proven
- Anti-corrosive aluminized body
- Straight-through performance design
- Deep exhaust note that demands attention
- Sound of horsepower from idle to full throttle
- Non-fiberglass acoustic packing for longevity & superior sound dampening



FOR AMERICAN MUSCLE, TRUCK, SUV & MORE

IMPORT • DOMESTIC

MagnaFlow's passenger car, sports car and compact performance applications have two series which identify basic performance and sound characteristics:

Street/Touring Series

Exhaust systems are designed for those seeking increased performance and better economy, balanced with interior and exterior noise levels. These systems are tested against SAE j1169 standards.

Competition/Sport Series

Exhaust systems are designed for those seeking maximum performance, reduced mass and an aggressive exhaust note that demands attention. These systems may not comply with all local or federal noise requirements.

Exit Configurations

EXIT STYLE CONFIGURATIONS:

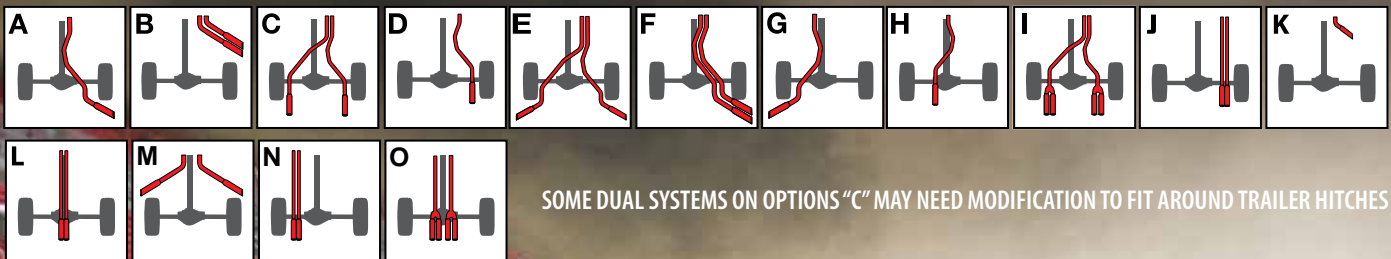

SOME DUAL SYSTEMS ON OPTIONS "C" MAY NEED MODIFICATION TO FIT AROUND TRAILER HITCHES



MARIO ANDRETTI
Racing Legend



STIC • EUROPEAN

Stainless Steel mesh that provides durability Under high temperature, with additional Sound absorption and no blow-out.

Large diameter, performance Stainless steel core that eliminates flow restrictions Of louvered- style core.

Straight-through, one-piece core for smooth, unrestricted flow. Dramatically reduced back pressure

All-welded, lap-jointed Contacts avoid distortion and cracking at the joints.

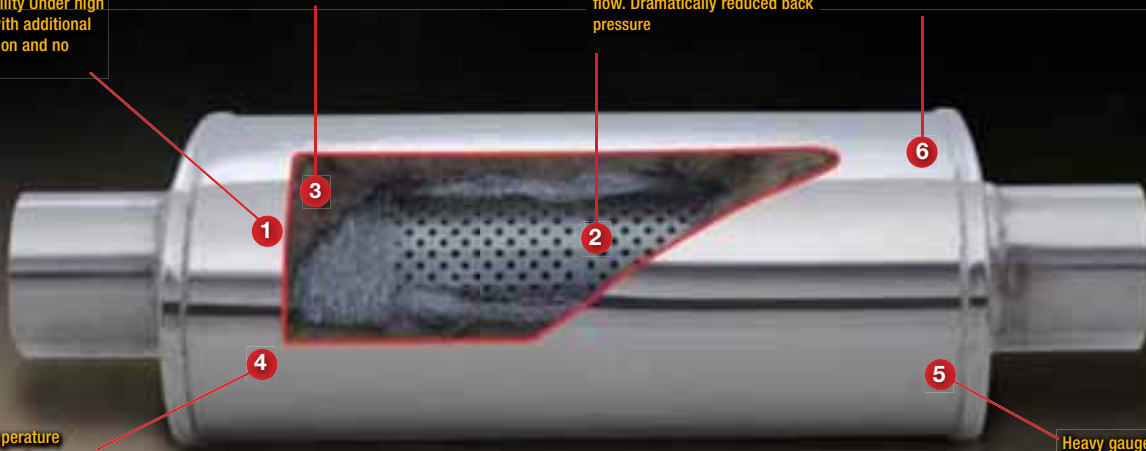

Body a high temperature acoustical Suppression material to fill the body Of the converter for maximum sound absorption.

Heavy gauge stainless steel body, end caps and one-piece core that deliver long life protection



CHIP FOOSE
Legendary Car Builder



Car Applications

ACURA		Exit Style	Part #
INTEGRA			
2000-2001	L4 1.8L; Coupe; GS-R		
	2.25 in. Cat-Back	D	15653
1994-2001	L4 1.8L; Coupe; GS, LS, RS		
	2.25 in. Cat-Back	D	15653
1994-1999	L4 1.8L; Coupe; GS-R		
	2.25 in. Cat-Back	D	15652
1994-1999	L4 1.8L; Sedan; GS-R		
	2.25 in. Cat-Back	D	15651
RSX			
2002-2005	L4 2.0L; Excl. Type S		
	2.25 in. Cat-Back w/ 4" tip	D	15783
	2.25 in. Cat-Back w/ 5" tip	D	15726
2002-2005	L4 2.0L; Type S		
	2.25 in. Cat-Back w/ 5" tip	D	15729
	2.25 in. Cat-Back w/ 4" tip	D	15783
AUDI			
A3			
2009-2012	L4 2.0L Turbocharged; Quattro		
	3 in. Cat-Back	N	15525
2006-2012	L4 2.0L Turbocharged		
	3 in. Cat-Back	N	16716
2006-2009	V6 3.2L; Quattro		
	2.5 in. Cat-Back Sport	N	15598
	2.5 in. Cat-Back Touring	N	16717
A4			
2009-2012	L4 2.0L Turbocharged; FWD		
	3 in. Cat-Back	N	16587
2006-2008	L4 2.0L Turbocharged; FWD		
	2.25,2.5 in. Cat-Back	C	16680
2005-2005	L4 2.0L; FWD		
	2.25,2.5 in. Cat-Back	C	16600
2002-2005	L4 1.8L; FWD		
	2.25,2.5 in. Cat-Back	C	16600
A4 QUATTRO			
2009-2012	L4 2.0L Turbocharged; AWD		
	3 in. Cat-Back Sport	N	15519
	3 in. Cat-Back Touring	N	16588
2008-2009	V6 3.2L; AWD		
	2.25 in. Cat-Back	C	15833
2006-2008	L4 2.0L Turbocharged; AWD		
	2.25,2.5 in. Cat-Back	C	16601
2002-2005	L4 1.8L Turbocharged; AWD		
	2.25,2.5 in. Cat-Back	C	16601
1998-2001	L4 1.8L Turbocharged; AWD		
	3 in. Cat-Back	N	16494
A5 QUATTRO			
2010-2012	L4 2.0L Turbocharged; AWD		
	2.5 in. Cat-Back Sport	H	16475
	2.5 in. Cat-Back Touring	H	16476
2009-2012	V6 3.2L; AWD		
	2.5 in. Cat-Back	C	16597
A6			
2000-2004	V6 2.7L Turbocharged; AWD		
	2.5 in. Cat-Back	C	16493
A6 QUATTRO			
2009-2011	V8 4.2L; Sedan; AWD		
	2.5 in. Cat-Back	C	16599
2000-2003	V8 4.2L; AWD		
	2.5 in. Cat-Back	C	16477
A8 QUATTRO			
2006-2007	V8 4.2L; AWD		
	2.5 in. Cat-Back	C	16492
R8			
2008-2011	V8 4.2L		
	2.5 in. Cat-Back Reuses Factory Fascia-Tip	C	16735
RS4			
2007-2008	V8 4.2L		
	2.5 in. Cat-Back	I	16689
S4			
2010-2012	V6 3.0L; Supercharged		
	2.25 in. Cat-Back	I	15599
2004-2006	V8 4.2L		
	2.5 in. Cat-Back	C	16586
2000-2002	V6 2.7L; Sedan		
	2.25,2.5 in. Cat-Back	N	16585

AUDI		Exit Style	Part #
S4			
2000-2002	V6 2.7L; Wagon		
	2.25,2.5 in. Cat-Back	N	16769
S5			
2009-2012	V8 4.2L		
	2.5 in. Cat-Back	I	16598
S6			
2009-2011	V10 5.2L; Sedan		
	3 in. Cat-Back	I	16499
TT			
2008-2009	L4 2.0L Turbocharged		
	3 in. Cat-Back	N	16718
2000-2006	L4 1.8L Turbocharged		
	2.5 in. Cat-Back	H	16733
TT QUATTRO			
2009-2011	L4 2.0L Turbocharged; S Models, AWD		
	2.5 in. Cat-Back	I	16491
2008-2009	V6 3.2L; AWD		
	2.5 in. Cat-Back Sport	C	16994
	3 in. Cat-Back Touring	C	16719
2004-2006	V6 3.2L; AWD		
	3 in. Cat-Back	C	16737
2000-2006	L4 1.8L; AWD		
	2.5 in. Cat-Back	D	16738
	2.5 in. Cat-Back	C	16739
BMW			
128i			
2011-2011	L6 3.0L		
	2.5 in. Cat-Back	N	15526
2008-2010	L6 3.0L		
	2.5 in. Cat-Back	N	16525
135i			
2011-2011	L6 3.0L; Turbocharged; Excl Convertible		
	2.5,3 in. Cat-Back Sport	N	15527
2008-2010	L6 3.0L; Turbocharged		
	3 in. Cat-Back	N	16526
318i			
1996-1999	L4 1.9L		
	2.5 in. Cat-Back	N	16527
1984-1985	L4 1.8L		
	2 in. Cat-Back	D	16530
318iC			
1996-1999	L4 1.9L		
	2.5 in. Cat-Back	N	16527
1991-1992	L4 1.8L		
	2.5 in. Cat-Back	N	16531
318iS			
1996-1999	L4 1.9L		
	2.5 in. Cat-Back	N	16527
1991-1991	L4 1.8L		
	2.5 in. Cat-Back	N	16531
318Ti			
1996-1999	L4 1.9L		
	2.5 in. Cat-Back	N	16528
323i			
1998-2000	L6 2.5L; Excl. Convertible		
	2.25,2.5 in. Cat-Back	N	16532
323iC			
1998-2000	L5 2.5L; Excl. Convertible		
	2.25,2.5 in. Cat-Back	N	16532
323iS			
1998-2000	L6 2.5L; Excl. Convertible		
	2.25,2.5 in. Cat-Back	N	16532
325Ci			
2001-2005	L6 2.5L; Excl. Convertible		
	2.25,2.5 in. Cat-Back	H	16748
325E			
1984-1987	L6 2.7L		
	2.5 in. Cat-Back	N	16536
325ES			
1986-1987	L6 2.7L		
	2.5 in. Cat-Back	N	16536
325i			
2001-2005	L6 2.5L		
	2.25,2.5 in. Cat-Back	H	16748

BMW	Exit Style	Part #
325i		
1992-1995 L6 2.5L; Excl. Convertible		
2.25 in. Cat-Back	N	16534
1987-1991 L6 2.5L		
2.5 in. Cat-Back	N	16535
325iS		
1992-1995 L6 2.5L; Excl. Convertible		
2.25 in. Cat-Back	N	16534
1987-1991 L6 2.5L		
2.5 in. Cat-Back	N	16535
325iX		
1988-1991 L6 2.5L		
2.5 in. Cat-Back	N	16535
328Ci		
1999-2000 L6 2.8L; Excl. Convertible		
2.25,2.5 in. Cat-Back	N	16532
328i		
2011-2011 L6 3.0L; Turbocharged		
2.5 in. Cat-Back	N	15528
2007-2010 L6 3.0L		
2.5 in. Cat-Back	N	16537
1999-2000 L6 2.8L; Excl. Convertible		
2.25,2.5 in. Cat-Back	N	16532
1996-1998 L6 2.8L; Excl. Convertible		
2.25 in. Cat-Back	N	16603
328iC		
1999-2000 L6 2.8L		
2.25,2.5 in. Cat-Back	N	16532
328iS		
1996-1998 L6 2.8L; Excl. Convertible		
2.25 in. Cat-Back	N	16603
328Xi		
2011-2011 L6 3.0L; Turbocharged		
2.5 in. Cat-Back	N	15528
2007-2010 L6 3.0L		
2.5 in. Cat-Back	N	16537
330Ci		
2001-2005 L6 3.0L; Excl. Convertible		
2.25,2.5 in. Cat-Back Touring	N	16533
330i		
2006-2007 L6 3.0L; Excl. Convertible		
2.25,2.5 in. Cat-Back	N	16539
2001-2005 L6 3.0L; Excl. Convertible		
2.25,2.5 in. Cat-Back Touring	N	16533
330Xi		
2006-2007 L6 3.0L; Excl. Convertible		
2.25,2.5 in. Cat-Back	N	16539
335i		
2011-2011 L6 3.0L; Turbocharged; Coupe		
2.5 in. Cat-Back Sport	C	15529
2.5 in. Cat-Back Touring	C	16388
2011-2011 L6 3.0L; Turbocharged; Sedan		
2.5 in. Cat-Back Sport	C	15541
2.5 in. Cat-Back Touring	C	16387
2007-2010 L6 3.0L; Turbocharged; Coupe		
2.5 in. Cat-Back Sport	C	16540
2.5 in. Cat-Back Touring	C	15586

BMW	Exit Style	Part #
335i		
2007-2010 L6 3.0L; Turbocharged; Sedan		
2.5 in. Cat-Back Sport	C	16542
2.5 in. Cat-Back Touring	C	15587
335Xi		
2011-2011 L6 3.0L; Turbocharged; Coupe, Excl. 4WD		
2.5 in. Cat-Back Sport	C	15529
2011-2011 L6 3.0L; Turbocharged; Sedan, Excl. 4WD		
2.5 in. Cat-Back Sport	C	15541
2007-2010 L6 3.0L; Turbocharged; Coupe		
2.5 in. Cat-Back Sport	C	16540
2.5 in. Cat-Back Touring	C	15586
2007-2010 L6 3.0L; Turbocharged; Sedan		
2.5 in. Cat-Back Sport	C	16542
2.5 in. Cat-Back Touring	C	15587
525i		
2006-2008 L6 3.0L		
2.25,2.5 in. Cat-Back	N	16551
2004-2005 L6 2.5L		
2.25,2.5 in. Cat-Back	N	16551
1991-1995 L6 2.5L		
2.25,2.5 in. Cat-Back	C	16544
1987-1990 L6 2.5L		
2.25,2.5 in. Cat-Back	C	16545
528E		
1987-1988 L6 2.7L; From 3/87		
2.25,2.5 in. Cat-Back	H	16548
1982-1987 L6 2.7L; To 3/87		
2.25,2.5 in. Cat-Back	N	16549
528i		
2011-2011 L6 3.0L		
2.5 in. Cat-Back	N	15500
2008-2010 L6 3.0L		
2.25,3 in. Cat-Back Touring	N	15542
1999-2000 L6 2.8L		
2.25,2.5 in. Cat-Back	H	16546
1997-1998 L6 2.8L		
2.25,2.5 in. Cat-Back	H	16547
530i		
2004-2007 L6 3.0L		
2.25,2.5 in. Cat-Back	N	16551
2001-2003 L6 3.0L		
2.25,2.5 in. Cat-Back	H	16550
1994-1995 V8 3.0L		
2.25,2.5 in. Cat-Back	N	16552
535i		
2011-2011 L6 3.0L; Turbocharged		
2.5 in. Cat-Back Touring	C	15543
2008-2010 L6 3.0L; Turbocharged		
2.25,2.5 in. Cat-Back	N	16553
1989-1993 L6 3.5L		
2.25,2.5 in. Cat-Back	N	16554
1985-1988 L6 3.5L		
2.25,2.5 in. Cat-Back	N	16555
535iS		
1988-1988 L6 3.5L		
2.25,2.5 in. Cat-Back	N	16555

EXIT STYLE CONFIGURATIONS:

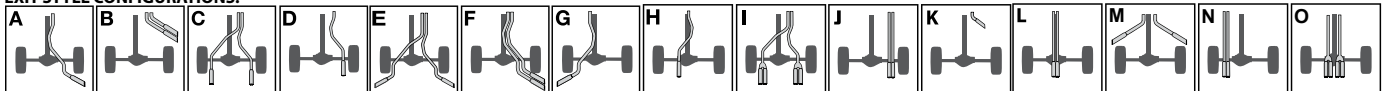

SOME DUAL SYSTEMS ON OPTIONS "C" MAY NEED MODIFICATION TO FIT AROUND TRAILER HITCHES

“The Sound of the car completes the experience, you wanna hear those horses...the engine is talking to you. I’m Mario Andretti and when I drive I don’t want to feel the experience I want to hear it.”

– Mario Andretti, Legendary Racer



Car Applications

BMW		Exit Style	Part #
540I			
1999-2000	V8 4.4L		
	3 in. Cat-Back	H	16556
1997-1998	V8 4.4L		
	2.5,3 in. Cat-Back	H	16557
545I			
2004-2005	V8 4.4L		
	2.5,3.5 in. Cat-Back	N	16558
550I			
2011-2011	V8 4.4L; Turbocharged		
	2.5 in. Cat-Back	C	15499
2006-2010	V8 4.8L		
	3 in. Cat-Back	N	16559
645CI			
2004-2005	V8 4.4L		
	2.5 in. Cat-Back	C	16560
650I			
2006-2011	V8 4.8L		
	2.5 in. Cat-Back	C	16560
M1			
2012-2012	L6 3.0L; Turbocharged		
	2.5 in. Cat-Back	I	15071
M3			
2012-2012	V6 3.3L; Turbocharged Coupe		
	Cat-Back	I	15051
2012-2012	V6 3.3L; Turbocharged Sedan		
	Cat-Back	I	15052
2011-2011	V8 4.0L; Coupe		
	2.5 in. Cat-Back	I	15544
2011-2011	V8 4.0L; Sedan		
	2.5 in. Cat-Back	I	15545
2008-2010	V8 4.0L; Coupe		
	2.5 in. Cat-Back	I	16814
2008-2010	V8 4.0L; Sedan		
	2.5 in. Cat-Back	I	16524
2001-2006	L6 3.2L; Coupe		
	2.25,2.5 in. Cat-Back	I	16602
1996-1999	L6 3.2L; Excl. Convertible		
	2.5 in. Cat-Back	N	16604
1995-1995	L6 3.0L		
	2.5 in. Cat-Back	N	16604
M5			
2011-2011	V10 5.0L; Turbocharged		
	2.5 in. Cat-Back	I	15546
2006-2010	V10 5.0L		
	2.5 in. Cat-Back	I	16859
2000-2003	V8 5.0L		
	2.5 in. Cat-Back	I	16858
M6			
2011-2011	V10 5.0L; Turbocharged		
	2.5 in. Cat-Back	I	15547
2006-2010	V10 5.0L		
	2.5 in. Cat-Back	I	16754
Z3			
2001-2002	L6 2.5L		
	2 in. Cat-Back	J	16465
2001-2002	L6 3.0L		
	2 in. Cat-Back	J	16465
1997-2000	L6 2.8L		
	2.5 in. Cat-Back	H	16712
BUICK			
APOLLO			
1973-1974	V8 5.7L; 350 CID		
	2.5 in. X-Member-Back	D	16610
	3 in. X-Member-Back	D	16611

BUICK		Exit Style	Part #
GS			
1970-1972	V8 5.7L; 350 CID		
	2.5 in. X-Member-Back	D	15894
	3 in. X-Member-Back	E	15898
	2.5 in. Manifold Pipe w/ 3.0in. Adaptors		16442
GS 350			
1968-1969	V8 5.7L; 350 CID		
	2.5 in. X-Member-Back	D	15894
	3 in. X-Member-Back	E	15898
	2.5 in. Manifold Pipe w/ 3.0in. Adaptors		16442
GS 400			
1968-1969	V8 6.6L; 400 CID		
	2.5 in. X-Member-Back	D	15894
	3 in. X-Member-Back	E	15898
	2.5 in. Manifold Pipe w/ 3.0in. Adaptors		16443
GS 455			
1970-1972	V8 7.5L; 455 CID		
	2.5 in. X-Member-Back	D	15894
	3 in. X-Member-Back	E	15898
	2.5 in. Manifold Pipe w/ 3.0in. Adaptors		16443
REGAL			
2011-2011	L4 2.0L; Turbocharged		
	2.5 in. Cat-Back	C	15498
2011-2011	L4 2.4L		
	2.5 in. Cat-Back	C	15498
1987-1987	V6 3.8L Turbocharged; GNX		
	2.5 in. Cat-Back	C	16884
1984-1987	V6 3.8L Turbocharged; Grand National; T-Type		
	2.5 in. Cat-Back	C	16884
SKYLARK			
1968-1972	V8 5.7L; 350 CID		
	2.5 in. X-Member-Back	D	15894
	3 in. X-Member-Back	E	15898
	2.5 in. Manifold Pipe w/ 3.0in. Adaptors		16442
1968-1972	V8 Big Block; 400/455 CID		
	2.5 in. X-Member-Back	D	15894
	3 in. X-Member-Back	E	15898
	2.5 in. Manifold Pipe w/ 3.0in. Adaptors		16443
1964-1967	All V8		
	2.5 in. X-Member-Back	D	15893
	3 in. X-Member-Back	E	15897
	2.5 in. Manifold Pipe w/ 3.0in. Adaptors		16441
CADILLAC			
CTS			
2011-2012	V6 3.6L; Coupe; Excl. AWD		
	2.5 in. Cat-Back	L	15073
2011-2012	V8 6.2L Supercharged; Coupe; V-Series		
	2.5 in. Cat-Back	L	15496
2010-2012	V6 3.0L; Sedan; Excl. AWD		
	2.25 in. Cat-Back	C	16831
2009-2012	V8 6.2L Supercharged; Sedan; V-Series		
	2.5 in. Cat-Back	C	16866
2008-2012	V6 3.6L; Sedan; Excl. AWD		
	2.25 in. Cat-Back	C	16831
2006-2007	V8 6.0L		
	2.5 in. Cat-Back	C	16637
2004-2005	V8 5.7L		
	2.5 in. Cat-Back	C	16636
XLR			
2006-2009	V8 4.4L Supercharged; V-Series		
	2.5 in. Cat-Back	I	16794
2004-2009	V8 4.6L		
	2.5 in. Cat-Back	I	16794

EXIT STYLE CONFIGURATIONS:

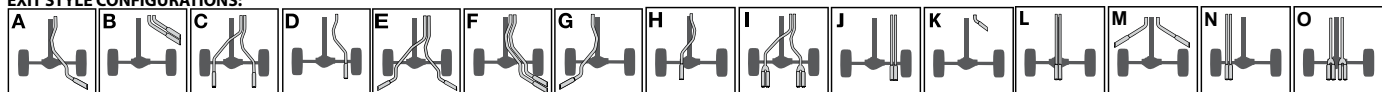

SOME DUAL SYSTEMS ON OPTIONS "C" MAY NEED MODIFICATION TO FIT AROUND TRAILER HITCHES

CHEVROLET Exit Style Part #

BEL AIR

1957-1957	V8 4.6L; 283 CID		
	3 in. X-Member-Back	D	16596
1955-1957	V6 3.9L; 235 CID		
	2.5 in. X-Member-Back	D	16792
	3 in. X-Member-Back	D	16596
1955-1957	V8 4.3L; 265CID		
	2.5 in. X-Member-Back	D	16792
	3 in. X-Member-Back	D	16596
1955-1957	V8 5.7L; Ram Horn; 3-Bolt Manifold		
	2.5 in. Manifold Pipe w/ 3.0in. Adaptors		16461

CAMARO

2012-2012	V8 6.2L Supercharged; ZL1		
	Cat-Back	I	15053
2011-2012	V8 6.2L; Excl. Convertible		
	2.5 in. Cat-Back Competition	L	15086
2010-2012	V6 3.6L		
	2.5 in. Cat-Back Street	C	16583
	2.5 in. Axle-Back Street	C	16584
2010-2012	V8 6.2L; Excl. Convertible		
	3 in. Cat-Back Competition	C	16483
2010-2012	V8 6.2L; Incl. Convertible		
	2.5 in. Axle-Back Street	C	15092
	2.5 in. Axle-Back Street GM PERFORMANCE PARTS FASCIA	C	15096
	2.5 in. Axle-Back Competition	C	15093
	2.5 in. Cat-Back Street	C	15089
	2.5 in. Cat-Back Street GM PERFORMANCE PARTS FASCIA	C	15094
	2.5 in. Cat-Back Competition	C	15090
	2.5 in. Cat-Back Competition GM PERFORMANCE PARTS FASCIA ONLY	C	15095
2010-2010	V8 6.2L; Excl. Convertible		
	2.5 in. Axle-Back Street	C	16581
	2.5 in. Axle-Back Street GM PERFORMANCE PARTS FASCIA	C	16480
	2.5 in. Axle-Back Competition	C	16582
	2.5 in. Cat-Back Street	C	16579
	2.5 in. Cat-Back Street GM PERFORMANCE PARTS FASCIA	C	16481
	2.5 in. Cat-Back Competition	C	16580
	2.5 in. Cat-Back Competition GM PERFORMANCE PARTS FASCIA ONLY	C	16482
1998-2002	V6 3.8L		
	2.5 in. Cat-Back	C	15693
1998-2002	V8 5.7L; Z-28/SS		
	2.5,3 in. Cat-Back	C	15684
	2.5,3 in. Cat-Back	O	16846
	2.5,3 in. Cat-Back	I	16723
1995-1997	V6 3.8L		
	2.5 in. Cat-Back	C	15694
1993-1997	V8 5.7L		
	2.5,3 in. Cat-Back	C	15620
1993-1995	V6 3.4L		
	2.5 in. Cat-Back	C	15694
1987-1992	V8 5.7L		
	2.5,3 in. Cat-Back	C	16829
1987-1989	V8 5.7L		
	2.5,3 in. Manifold Pipe Y-pipe Assy.		16450
1986-1989	V8 5.0L		
	2.5,3 in. Manifold Pipe Y-pipe Assy.		16450
1983-1992	V8 5.0L		
	2.5,3 in. Cat-Back	C	16829

CHEVROLET Exit Style Part #

CAMARO

1976-1979	V8 5.0L; 307CID		
	2.5 in. Cat-Back	C	16828
	2.2,2.5 in. Manifold Pipe Y-pipe Assy.		16447
1975-1979	V8 5.7L; 350 CID		
	2.5 in. Cat-Back	C	16828
	2.2,2.5 in. Manifold Pipe Y-pipe Assy.		16447
1970-1974	V8 Small Block; 307/350 CID *		
	3 in. X-Member-Back	E	15899
	2.5 in. Manifold Pipe w/ 3.0in. Adaptors		16826
	2.5 in. Manifold Pipe 3 Bolt Flange; w/ 3.0in. Adaptors		16434
1970-1972	V8 Big Block; 396/402 CID *		
	3 in. X-Member-Back	E	15899
	2.5 in. Manifold Pipe w/ 3.0in. Adaptors		16826
	2.5 in. Manifold Pipe 3 Bolt Flange; w/ 3.0in. Adaptors		16435
1967-1969	V8 Big Block; 396/427 CID *		
	2.5 in. X-Member-Back	E	15896
	3 in. X-Member-Back	E	15899
	2.5 in. X-Member-Back	E	15895
	2.5 in. Manifold Pipe 3 Bolt Flange; w/ 3.0in. Adaptors		16435
1967-1969	V8 Small Block; 302/307/327/350 CID *		
	2.5 in. X-Member-Back	E	15896
	3 in. X-Member-Back	E	15899
	2.5 in. X-Member-Back	E	15895
	2.5 in. Manifold Pipe 3 Bolt Flange; w/ 3.0in. Adaptors		16434

CAVALIER

1996-2005	L4 2.2L		
	2.25 in. Cat-Back	N	15761
	2.25 in. Cat-Back	C	15762
1996-2002	L4 2.4L		
	2.25 in. Cat-Back	N	15761
	2.25 in. Cat-Back	C	15762

CHEVELLE

1970-1973	V8 7.4L; 454 CID		
	2.5 in. X-Member-Back	D	15894
	3 in. X-Member-Back	E	15898
1970-1972	V8 6.6L; 400 CID		
	2.5 in. X-Member-Back		15894
	3 in. X-Member-Back	E	15898
1969-1973	V8 5.7L; 350 CID		
	2.5 in. X-Member-Back	D	15894
	3 in. X-Member-Back	E	15898
1968-1973	V8 5.0L; 307 CID		
	2.5 in. X-Member-Back	D	15894
	3 in. X-Member-Back	E	15898
	2.5 in. Manifold Pipe w/ 3.0in. Adaptors		16442
1968-1969	V8 6.5L; 396 CID		
	3 in. X-Member-Back	E	15898
	2.5 in. X-Member-Back	D	15894
1968-1968	V8 5.4L; 327 CID		
	2.5 in. X-Member-Back	D	15894
	3 in. X-Member-Back	E	15898
1966-1967	V8 6.5L; 396 CID		
	3 in. X-Member-Back	E	15897
	2.5 in. X-Member-Back	D	15893
1964-1967	V8 4.6L; 283 CID		
	2.5 in. X-Member-Back	D	15893
	3 in. X-Member-Back	E	15897

EXIT STYLE CONFIGURATIONS:

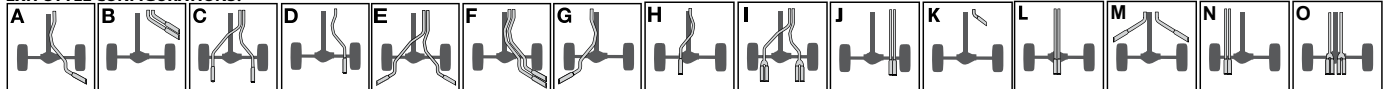

SOME DUAL SYSTEMS ON OPTIONS "C" MAY NEED MODIFICATION TO FIT AROUND TRAILER HITCHES

“Every Artist has their specialty, mine just happens to be Hot Rods. I don’t consider it to be a Foose Design until the engine sounds as great as that car looks. Every musical instruments has its own sound... Hot Rods are no different. MagnaFlow Performance Exhaust gives me that perfect sound.” – **Chip Foose, Legendary Car Builder**



Car Applications

CHEVROLET Exit Style Part #

CHEVELLE			
1964-1967	V8 5.4L; 327 CID		
	2.5 in. Manifold Pipe w/ 3.0in. Adaptors		16441
	3 in. X-Member-Back	E	15897
	2.5 in. X-Member-Back	D	15893

CHEVY II			
1968-1969	V8 5.0L; 307 CID		
	2.5 in. X-Member-Back	D	16610
	3 in. X-Member-Back	D	16611
1968-1969	V8 5.7L; 350 CID		
	2.5 in. X-Member-Back	D	16610
	3 in. X-Member-Back	D	16611
1968-1969	V8 6.5L; 396 CID		
	2.5 in. X-Member-Back	D	16610
	3 in. X-Member-Back	D	16611
1968-1968	V8 5.4L; 327 CID		
	2.5 in. X-Member-Back	D	16610
	3 in. X-Member-Back	D	16611

COBALT			
2008-2010	L4 2.0L Turbocharged; SS		
	3 in. Cat-Back	D	16875
2006-2008	L4 2.4L		
	2.5 in. Cat-Back	H	16619
2005-2010	L4 2.2L		
	2.25 in. Cat-Back	H	16618
2005-2007	L4 2.0L Supercharged; SS		
	2.5 in. Cat-Back	H	16619

CORVETTE			
2009-2012	V8 6.2L Supercharged; ZR-1		
	3 in. Cat-Back Competition	O	16839
	3 in. Cat-Back Street	I	16495
	3 in. Cat-Back Street	C	16670
2009-2012	V8 6.2L		
	2.5 in. Axle-Back Street	O	16593
	2.5 in. Performance Pipe Front Section		16462
2008-2011	V8 6.2L		
	2.5 in. Cat-Back MAGNAPACK	L	15887
	2.5 in. Cat-Back Street	O	15884
2008-2008	V8 6.2L		
	2.5 in. Performance Pipe Front Section		15885
	2.5 in. Axle-Back Street	O	15886
2006-2012	V8 7.0L Z06		
	3 in. Cat-Back Competition	O	16839
	3 in. Cat-Back Street	I	16495
	3 in. Cat-Back Street	C	16670
2005-2007	V8 6.0L		
	2.5 in. Cat-Back Street	O	15884
	2.5 in. Axle-Back Street	O	15886
	2.5 in. Cat-Back MAGNAPACK	L	15887
	2.5 in. Performance Pipe Front Section		15885
2000-2004	V8 5.7L		
	2.5 in. Cat-Back Competition	L	15763
2000-2004	V8 5.7L; Front		
	2.5 in. Performance Pipe w/o Converter		15479
1997-2004	V8 5.7L		
	2.5 in. Cat-Back Street	O	15660
	2.5 in. Axle-Back Street	O	15713
	2.5 in. Performance Pipe X-pipe assy		15437
	2.5 in. Axle-Back XL	O	16732
1997-1999	V8 5.7L		
	2.5 in. Performance Pipe w/o Converter		15479
1992-1996	V8 5.7L		
	3 in. Axle-Back	O	15623
	3 in. Cat-Back w/o Front Y-Pipe	O	16837
1986-1991	V8 5.7L		
	2.5 in. Cat-Back	I	15658
1982-1982	V8 5.7L; Y-Pipe Assy.		
	2.5,3 in. Manifold Pipe Y-pipe Assy.		16453

CHEVROLET Exit Style Part #

CORVETTE			
1980-1982	V8 5.7L		
	2.5 in. Cat-Back	C	16889
1980-1981	V8 5.7L; Y-Pipe Assy.		
	2.5,3 in. Manifold Pipe Y-pipe Assy.		16452
1975-1979	V8 5.7L		
	2.5 in. X-Member-Back	D	16710
1974-1974	V8 7.4L; 454 CID		
	2.5 in. X-Member-Back	C	16836
1970-1973	V8 5.7L; 350 CID		
	2.5 in. Cat-Back	C	16840
1970-1973	V8 7.4L; 454 CID		
	2.5 in. X-Member-Back w/ Square Fascia Cutouts	I	16841
1969-1973	V8 5.7L; 350 CID		
	2.25,2.5 in. X-Member-Back Originally Equipped w/ Side Pipes	L	16842
1968-1969	V8 5.7L		
	2.25,2.5 in. X-Member-Back w/ Round Bumper Cutouts	L	16799
1968-1968	V8 5.7L		
	2.25,2.5 in. X-Member-Back Originally Equipped w/ Side Pipes	L	16842
2011-2011	L4 1.4L; Turbocharged		
	2.25 in. Cat-Back	D	15495
2011-2011	L4 1.8L		
	2.25 in. Cat-Back	D	15495

CRUZE			
2011-2011	L4 1.4L; Turbocharged		
	2.25 in. Cat-Back	D	15495
2011-2011	L4 1.8L		
	2.25 in. Cat-Back	D	15495

HHR			
2008-2010	L4 2.0L Turbocharged		
	3 in. Cat-Back	H	16811
2006-2011	L4 2.2L		
	2.25 in. Cat-Back	H	16655
2006-2011	L4 2.4L		
	2.25 in. Cat-Back	H	16655

IMPALA			
2006-2011	V6 3.5L; 3.9L; Excl Fascia W/ Cutouts		
	2.5 in. Cat-Back	C	16708
2006-2009	V8 5.3L; SS		
	2.5 in. Cat-Back	C	16707
1959-1964	All L6, V8; 235/283/348/350/409/427 CID		
	2.5 in. X-Member-Back	C	16724

MALIBU			
2008-2011	L4 2.4L		
	2.5 in. Cat-Back	D	16505
2008-2011	V6 3.6L		
	2.5 in. Cat-Back	C	16506
1973-1973	V8 5.0L; 307 CID		
	2.5 in. X-Member-Back	D	15894
	3 in. X-Member-Back	E	15898
	2.5 in. Manifold Pipe w/ 3.0in. Adaptors		16441
1973-1973	V8 5.7L; 350 CID		
	2.5 in. X-Member-Back	D	15894
	3 in. X-Member-Back	E	15898
1973-1973	V8 7.4L; 454 CID		
	2.5 in. X-Member-Back	D	15894
	3 in. X-Member-Back	E	15898

1966-1967			
	V8 6.5L; 396 CID		
	2.5 in. X-Member-Back	D	15893
	3 in. X-Member-Back	E	15897
1964-1967	V8 4.6L; 283 CID		
	2.5 in. X-Member-Back	D	15893
	3 in. X-Member-Back	E	15897

1964-1967			
	V8 5.4L; 327 CID		
	2.5 in. X-Member-Back	D	15893
	3 in. X-Member-Back	E	15897
	2.5 in. Manifold Pipe w/ 3.0in. Adaptors		16441

MONTE CARLO			
2006-2007	V6 3.5L; 3.9L		
	2.5 in. Cat-Back	C	16728
2006-2007	V8 5.3L; SS		
	2.5 in. Cat-Back	C	16727

EXIT STYLE CONFIGURATIONS:

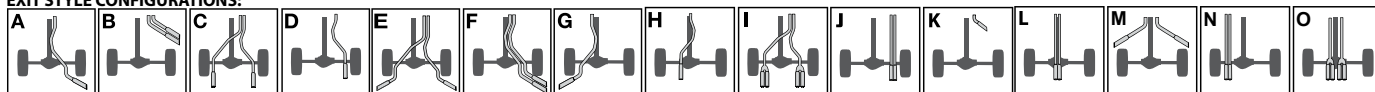

SOME DUAL SYSTEMS ON OPTIONS "C" MAY NEED MODIFICATION TO FIT AROUND TRAILER HITCHES

CHEVROLET Exit Style Part #

MONTE CARLO			
1983-1988	8 5.0L; SS		
	2.5 in. Cat-Back	C	16884
	2.5,3 in. Manifold Pipe Y-pipe Assy.		16451
1970-1973 V8 5.7L; 350 CID			
	2.5 in. X-Member-Back	D	15894
	3 in. X-Member-Back	E	15898
1970-1973 V8 6.6L; 400 CID			
	2.5 in. X-Member-Back	D	15894
	3 in. X-Member-Back	E	15898
1970-1973 V8 7.4L; 454 CID			
	2.5 in. X-Member-Back	D	15894
	3 in. X-Member-Back	E	15898

NOVA			
1968-1973	V8 Small Block; 307/327/350 CID		
	2.5 in. X-Member-Back	D	16610
	3 in. X-Member-Back	D	16611
	2.5 in. Manifold Pipe 3 Bolt Flange; w/ 3.0in. Adaptors		16434
1962-1967 V8 Small Block; 283/327 CID			
	2.5 in. Manifold Pipe 3 Bolt Flange; w/ 3.0in. Adaptors		16444

CHRYSLER

200			
2011-2012	V6 3.6L		
	2.5 in. Cat-Back	C	15097

300			
2005-2012	V6 2.7L/3.5L		
	2.5 in. Cat-Back	J	16629
	2.25,2.5 in. Cat-Back	I	16623

300C			
2012-2012	V8 6.4L		
	Cat-Back	C	15069
2005-2012 V8 5.7L			
	2.5 in. Cat-Back	C	15629

300C SRT-8 HEMI			
2005-2012	V8 6.1L		
	3 in. Cat-Back	C	16642

CROSSFIRE			
2004-2008	V6 3.2L		
	2,2.25 in. Cat-Back	L	16633

CROSSFIRE SRT-6			
2005-2006	V6 3.2L Supercharged		
	Cat-Back	L	15054

PT CRUISER			
2003-2009	L4 2.4L Turbocharged		
	2.5 in. Cat-Back	H	15860
2001-2010 L4 2.4L			
	2.25 in. Cat-Back	H	15680

SEBRING			
2007-2010	L4 2.4L; Sedan		
	2.25 in. Cat-Back	D	16813

DODGE

AVENGER			
2008-2009	L4 2.4L		
	2.25 in. Cat-Back	D	16813

CALIBER			
2012-2012	L4 1.4L		
	Cat-Back	D	15055
2008-2010 L4 2.4L Turbocharged; SRT-4			
	3 in. Cat-Back	D	16758

DODGE Exit Style Part #

CALIBER			
2007-2010	4 2.0L FWD		
	2.25 in. Cat-Back	D	16759
2007-2010 4 2.4L R/T; AWD			
	2.25 in. Cat-Back	D	16634

CHALLENGER			
2011-2012	V6 3.6L		
	2.5 in. Cat-Back	C	15098
	2.5 in. Cat-Back Reuses OEM Tip	C	15099
2009-2010 V6 3.5L			
	2.25,2.5 in. Cat-Back; Requires Rear Fascia Modifications	I	16500
	2.5 in. Cat-Back	D	16757
	2.25,2.5 in. Cat-Back Reuses OEM Tip	C	16484
1970-1972 All V8; 318/383/426/440 CID			
	3 in. X-Member-Back	C	15852
	2.5 in. X-Member-Back	C	15851

CHALLENGER R/T HEMI			
2009-2012	V8 5.7L Hemi		
	2.5 in. Cat-Back Competition	I	16515
	2.5 in. Cat-Back Competition Reuses OEM Tip	C	16516
	2.5 in. Cat-Back Street	I	16513
	2.5 in. Cat-Back Street Reuses OEM Tip	C	16514
	2.5 in. Axle-Back Street	I	16893
	2.5 in. Axle-Back Street	C	16894

CHALLENGER SRT-8 HEMI			
2011-2012	V8 6.4L		
	3 in. Cat-Back Competition	I	16885
	3 in. Cat-Back Competition Reuses OEM Tip	C	16886
	3 in. Cat-Back Street	I	16509
	3 in. Cat-Back Street Reuses OEM Tip	C	16510
	3 in. Axle-Back Street	I	16881
	3 in. Axle-Back Street	C	16882

2008-2010 V8 6.1L			
	3 in. Cat-Back Competition	I	16885
	3 in. Cat-Back Competition Reuses OEM Tip	C	16886
	3 in. Cat-Back Street	I	16509
	3 in. Cat-Back Street Reuses OEM Tip	C	16510
2008-2010 V8 6.1L			
	3 in. Axle-Back Street	I	16881
	3 in. Axle-Back Street	C	16882

CHARGER			
2011-2012	V6 3.6L		
	2.25, 2.5 in. Cat-Back Street	I	15082
	2.25,2.5 in. Cat-Back Street Reuses Factory Fascia-Tip	C	15492
2006-2010 V6 2.7L/3.5L			
	2.25,2.5 in. Cat-Back Street	C	16936
	2.25,2.5 in. Cat-Back Street	D	16635

CHARGER R/T HEMI			
2011-2012	V8 5.7L		
	2.5 in. Cat-Back Street	I	15083
	2.5 in. Cat-Back Street Reuses Factory Fascia-Tip	C	15493

2006-2010 V8 5.7L			
	2.5 in. Cat-Back Street	C	15628

CHARGER SRT-8 HEMI			
2011-2012	V8 6.4L		
	3 in. Cat-Back Street Reuses Factory Fascia-Tip	C	15494
2006-2010 V8 6.1L			
	3 in. Cat-Back Street	C	16642

EXIT STYLE CONFIGURATIONS:

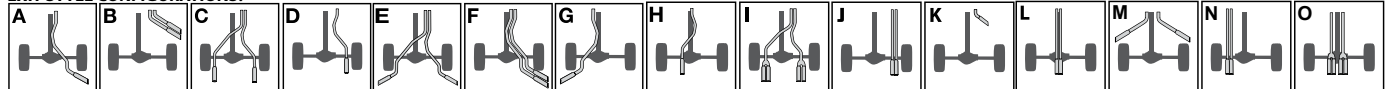

SOME DUAL SYSTEMS ON OPTIONS "C" MAY NEED MODIFICATION TO FIT AROUND TRAILER HITCHES

“On the track, I have to use the highest quality, best performing products. The same is true on the street....that's why I run MagnaFlow!”
- Marco Andretti, Indy Car Racer



Car Applications

DODGE Exit Style Part

MAGNUM			
2005-2009	V6 2.7L/3.5L		
	2.25, 2.5 in. Cat-Back	D	16635

MAGNUM R/T HEMI			
2005-2009	V8 5.7L		
	2.5 in. Cat-Back	C	15628

MAGNUM SRT-8 HEMI			
2006-2009	V8 6.1L		
	3 in. Cat-Back	C	16642

NEON			
2003-2005	L4 2.4L Turbocharged; SRT-4		
	2.5 in. Cat-Back	C	15786

2000-2005	L4 2.0L; Sedan; Excl. SXT & w/ sway bars		
	2.25 in. Cat-Back	C	15801

VIPER			
2011-2011	V10 8.4L; SRT-10		
	2.5 in. Cat-Back	M	15549

2008-2010	V10 8.4L; SRT-10		
	2.5 in. Cat-Back	M	16863

2003-2006	V10 8.3L		
	2.5 in. Cat-Back	M	16863

1996-2002	V10 8.0L; GTS		
	3 in. Cat-Back	L	16992

EAGLE

TALON

1995-1998	L4 2.0L; RS, GS; Excl. AWD		
	2.25 in. Cat-Back	H	15691

FIAT

500

2012-2012	L4 1.4L		
	2.25 in. Cat-Back	A	15088

FORD

CROWN VICTORIA

2006-2010	V8 4.6L		
	2.25 in. Cat-Back	C	16788

FIESTA

2011-2012	L4 1.6L		
	2.25 in. Cat-Back	J	16392

FOCUS

2012-2012	L4 2.0L		
	2.25 in. Cat-Back	H	15072

2010-2011	L4 2.0L		
	2.25 in. Cat-Back	D	15550

2008-2009	L4 2.0L; Coupe		
	2.25 in. Cat-Back	H	15864

2004-2006	L4 2.0L; Hatchback		
	2.25 in. Cat-Back	H	15826

2004-2006	L4 2.0L; Sedan		
	2.25 in. Cat-Back	H	15864

2004-2006	L4 2.3L; Sedan		
	2.25 in. Cat-Back	H	15864

2004-2004	L4 2.3L; Hatchback		
	2.25 in. Cat-Back	H	15826

2003-2003	L4 2.3L; Sedan; ZTS		
	2.25 in. Cat-Back	D	15697

2002-2004	L4 2.0L; Hatchback; SVT		
	2.25 in. Cat-Back	D	15743

2000-2003	L4 2.0L, 2.3L; Hatchback; ZX3, ZX5		
	2.25 in. Cat-Back	H	15682

2000-2003	L4 2.0L; Sedan		
	2.25 in. Cat-Back	D	15697

FUSION

2010-2012	L4 2.5L		
	2.25 in. Cat-Back	C	15551

2010-2012	V6 3.0L		
	2.25 in. Cat-Back	C	15552

FORD Exit Style Part

FUSION			
2010-2012	V6 3.5L; Sport		
	2.25 in. Cat-Back	C	15552

2006-2009	L4 2.3L		
	2.25 in. Cat-Back	J	16684

2006-2009	V6 3.0L; FWD		
	2.25 in. Cat-Back	C	16675

MUSTANG BOSS 302			
2012-2012	V8 5.0L		
	Cat-Back	C	15056

MUSTANG			
2011-2012	V8 5.0L		
	3 in. Axle-Back Competition; Requires Fascia Modification	I	15077

	3 in. Cat-Back Competition	C	15590
	3 in. Axle-Back Competition	C	15594
	3 in. Cat-Back Street	C	15589

	3 in. Axle-Back Street	C	15593
--	------------------------	---	-------

2011-2012	V6 3.7L		
	2.5 in. Performance Pipe Clamp-On Behind OEM Converter		16396

	2.5 in. Cat-Back Competition	C	15592
	2.5 in. Axle-Back Competition Requires Fascia Modification	I	15076

	2.5 in. Axle-Back Competition	C	15596
	2.5 in. Cat-Back Street	C	15591
	2.5 in. Axle-Back Street	C	15595

2011-2012	V8 5.4L Shelby GT500		
	3 in. Cat-Back Competition	C	15590

	3 in. Axle-Back Competition	C	15594
	3 in. Cat-Back Street	C	15589
	3 in. Axle-Back Street	C	15593

2010-2010	V6 4.0L		
	2.5 in. Cat-Back Requires OEM V8 Fascia or Modification	C	16575

	2.5 in. Cat-Back Street	J	16576
	2.5 in. Axle-Back Street	D	16577

	2.5 in. Performance Pipe Clamp-On Behind OEM Converter; V6 Single to V8 Dual Conversion		16458
	2.5 in. Cat-Back Competition; Requires Fascia Modification	I	15078

2010-2010	V8 4.6L; GT		
	2.5 in. Cat-Back Street	C	16570

	2.5 in. Axle-Back Competition No Mufflers	C	16578
	2.5 in. Axle-Back Street	C	16573

	2.5 in. Cat-Back MAGNAPACK	C	16571
	3 in. Cat-Back MAGNAPACK	C	16572

	2.5 in. Axle-Back MAGNAPACK	C	16574
	2.5 in. Performance Pipe Clamp-On Behind OEM Converter		16457

	2.5 in. Axle-Back Competition; Requires Fascia Modification	I	15075
--	---	---	-------

2010-2010	V8 4.6L; GT, Roush 427R Supercharged		
	2.5 in. Cat-Back Street	C	16570

	2.5 in. Axle-Back Competition No Mufflers	C	16578
	2.5 in. Axle-Back Street	C	16573

	2.5 in. Cat-Back MAGNAPACK	C	16571
	3 in. Cat-Back MAGNAPACK	C	16572

	2.5 in. Axle-Back MAGNAPACK	C	16574
--	-----------------------------	---	-------

2010-2010	V8 5.4L Shelby GT500		
	2.5 in. Cat-Back MAGNAPACK	C	16571

	3 in. Cat-Back MAGNAPACK	C	16572
	2.5 in. Axle-Back MAGNAPACK	C	16574

	2.5 in. Cat-Back Street	C	16570
	2.5 in. Axle-Back Competition No Mufflers	C	16578

	2.5 in. Axle-Back Street	C	16573
--	--------------------------	---	-------

2007-2009	V8 5.4L Shelby GT500		
	2.5 in. Axle-Back Street	C	15882

	2.5 in. Cat-Back Street	C	15881
	2.5 in. Axle-Back MAGNAPACK	C	16793

	3 in. Cat-Back MAGNAPACK	C	16674
	2.5 in. Cat-Back MAGNAPACK	C	15883

2005-2009	V6 4.0L		
	2.5 in. Performance Pipe Clamp-On Behind OEM Converter		16411

	2.5 in. Axle-Back	D	15889
	2.5 in. Cat-Back Under the Fascia	C	16605

EXIT STYLE CONFIGURATIONS:



SOME DUAL SYSTEMS ON OPTIONS "C" MAY NEED MODIFICATION TO FIT AROUND TRAILER HITCHES

FORD		Exit Style	Part #
MUSTANG			
2005-2009	V8 4.6L		
	2.5 in. Cat-Back Street	C	15881
	2.5 in. Axle-Back Competition No Mufflers	C	16843
	2.5 in. Axle-Back Street	C	15882
	2.5 in. Cat-Back MAGNAPACK	C	15883
	3 in. Cat-Back MAGNAPACK	C	16674
	2.5 in. Axle-Back MAGNAPACK	C	16793
	2.5 in. Performance Pipe Clamp-On Behind OEM Converter		15485
2001-2001	V8 4.6L Bullitt		
	2.5 in. Cat-Back MAGNAPACK	C	15673
	3 in. Cat-Back Competition	C	16394
1999-2004	V6 3.8L		
	2.5 in. Cat-Back	C	15717
1999-2004	V8 4.6L Cobra		
	2.5 in. Cat-Back	C	15644
1999-2004	V8 4.6L GT, Mach I		
	2.5 in. Cat-Back Street	C	15671
	2.5 in. Cat-Back MAGNAPACK	C	15673
	3 in. Cat-Back Competition	C	16394
1996-2004	V8 4.6L		
	2.5 in. Cat-Back Off-Road Pro	K	17118
1996-1998	V8 4.6L; Cobra		
	2.5 in. Cat-Back Street	C	15638
	2.5 in. Cat-Back MAGNAPACK	C	15677
1996-1998	V8 4.6L; GT, Mach 1, Bullitt		
	2.5 in. Cat-Back Street	C	15638
	2.5 in. Cat-Back MAGNAPACK	C	15677
1994-1995	V8 5.0L; GT; Cobra		
	2.5 in. Cat-Back Street	C	15638
	2.5 in. Cat-Back MAGNAPACK	C	15677
1987-1993	V8 5.0L GT		
	2.5 in. Cat-Back Street	C	15632
	3 in. Cat-Back Competition	C	16996
	2.5 in. Cat-Back Competition Magnapack	C	16995
1987-1993	V8 5.0L LX, Cobra		
	2.5 in. Cat-Back	C	15630
1986-1995	V8 5.0L		
	2.5 in. Cat-Back Off-Road Pro	K	17118
1986-1986	V8 5.0L LX		
	2.5 in. Cat-Back	C	15630
1969-1970	V8 5.8L; 351 CID; Excl Staggered Shock		
	2.5 in. X-Member-Back Requires Modification for Convertible	Options	15816
	3 in. X-Member-Back Requires Modification for Convertible	Options	15819
1969-1970	V8 5.8L; 351 CID		
	2.5 in. Manifold Pipe 2 Bolt Flange; w/ 3.0in. Adaptors		16446
1968-1970	V8 5.0L; 302 CID; Excl Staggered Shock		
	2.5 in. X-Member-Back Requires Modification for Convertible	Options	15816
	3 in. X-Member-Back Requires Modification for Convertible	Options	15819
1968-1970	V8 5.0L; 302 CID		
	2.5 in. Manifold Pipe 2 Bolt Flange; w/ 3.0in. Adaptors		16446
1968-1970	V8 7.0L; 428 CID; Excl Staggered Shock		
	2.5 in. X-Member-Back Requires Modification for Convertible	Options	15816
	3 in. X-Member-Back Requires Modification for Convertible	Options	15819
1967-1969	V8 6.4L; 390 CID		
	2.5 in. X-Member-Back Requires Modification for Convertible	Options	15816
	3 in. X-Member-Back Requires Modification for Convertible	Options	15819

FORD		Exit Style	Part #
MUSTANG			
1967-1968	V8 4.7L; 289 CID; 302 CID; Excl Staggered Shock		
	2.5 in. X-Member-Back Requires Modification for Convertible	Options	15816
	3 in. X-Member-Back Requires Modification for Convertible	Options	15819
1964-1966	V8 4.7L; 289 CID		
	2.5 in. Manifold Pipe 3 Bolt Flange; w/ 3.0in. Adaptors		16445
1964-1966	V8 4.7L; 289 CID; Excl Staggered Shock		
	3 in. X-Member-Back Requires Modification for Convertible	C	15817
	2.5 in. X-Member-Back Requires Modification for Convertible	C	15815
1964-1964	V8 4.3L; 260 CID		
	3 in. X-Member-Back Requires Modification for Convertible	C	15817
TAURUS			
2010-2010	6 3.5L; SHO		
	2.5 in. Cat-Back	C	15769
HONDA			
ACCORD			
2008-2009	V6 3.5L; Coupe		
	2.25 in. Cat-Back	C	16817
2006-2007	V6 3.0L; Sedan		
	2.25, 2.5 in. Cat-Back	C	16685
2003-2007	V6 3.0L; Coupe		
	2, 2.25 in. Cat-Back	C	16686
2003-2005	V6 3.0L; Sedan		
	2, 2.25 in. Cat-Back	C	15800
2001-2002	L4 2.3L; Sedan		
	2.25 in. Cat-Back	D	15647
1998-2002	V6 3.0L; Coupe, Sedan		
	2, 2.25 in. Cat-Back	C	15640
1998-2000	L4 2.3L; Sedan		
	2.25 in. Cat-Back	D	15690
1994-1997	L4 2.2L; Coupe, Sedan		
	2.25 in. Cat-Back	D	15686
1990-1993	L4 2.2L; Coupe, Sedan		
	2.25 in. Cat-Back	D	15687
CIVIC			
2012-2012	L4 2.4L Si, Coupe		
	Cat-Back	D	15057
2012-2012	L4 2.4L Si, Sedan		
	Cat-Back	D	15058
2007-2011	L4 2.0L Si, Sedan		
	2.25 in. Cat-Back	D	16819
2006-2011	L4 1.8L; Coupe; DX, LX, EX		
	2.25 in. Cat-Back	D	16687
2006-2011	L4 1.8L; Sedan		
	2.25 in. Cat-Back	D	16818
2006-2011	L4 2.0L; Coupe		
	2.25 in. Cat-Back	D	16688
2002-2005	L4 2.0L; Hatchback; Si		
	2.25 in. Cat-Back	J	15757
2001-2005	L4 1.7L; Coupe, Sedan; DX, LX, EX		
	2.25 in. Cat-Back	D	15712
1999-2000	L4 1.6L; Coupe; Si		
	2.25 in. Cat-Back	D	15646
1996-2000	L4 1.6L; Coupe, Sedan; DX, LX		
	2.25 in. Cat-Back	D	15642

EXIT STYLE CONFIGURATIONS:

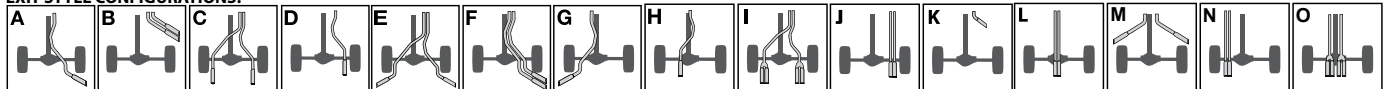

SOME DUAL SYSTEMS ON OPTIONS "C" MAY NEED MODIFICATION TO FIT AROUND TRAILER HITCHES

"I don't care if I'm driving one of my race cars or the tow truck, when I'm listening to the exhaust I want to hear that sound of power. MagnaFlow has that perfect combination of great sound and great performance" – **"Big Daddy" Don Garlits, Drag Racing Legend**



Car Applications

HONDA

		Exit Style	Part #
CIVIC			
1996-2000	L4 1.6L; Coupe, Sedan; EX		
	2.25 in. Cat-Back	D	15646
1996-2000	L4 1.6L; Hatchback; CX, DX		
	2.25 in. Cat-Back	D	15643
1992-1995	L4 1.5L; Hatchback; CX, VX		
	2.25 in. Cat-Back	D	15643
1992-1995	L4 1.5L; Hatchback; DX		
	2.25 in. Cat-Back	D	15645
1992-1995	L4 1.6L; Coupe, Sedan; EX		
	2.25 in. Cat-Back	D	15641
1992-1995	L4 1.6L; Hatchback		
	2.25 in. Cat-Back	D	15645

CR-Z			
2011-2011	L4 1.5L		
	2 in. Cat-Back	J	15491

S2000			
2004-2005	L4 2.2L		
	2.5 in. Cat-Back	C	15831
2001-2003	L4 2.0L		
	2.5 in. Cat-Back	C	15831

HYUNDAI

GENESIS SEDAN			
2012-2012	V8 5.0L; R-Spec		
	2.5 in. Cat-Back	C	15059
2009-2012	V8 4.6L; Sedan		
	2.5 in. Cat-Back	I	16497

GENESIS COUPE			
2010-2012	L4 2.0L; Turbocharged		
	2.3 in. Cat-Back	I	16478
2009-2012	V6 3.8L		
	2.25 in. Cat-Back	I	16507

VELOSTER			
2012-2012	L4 1.6L		
	Cat-Back	L	15060

INFINITI

G35			
2007-2008	V6 3.5L; Sedan		
	2.5 in. Cat-Back	C	16862
2003-2007	V6 3.5L; Coupe		
	2.5 in. Cat-Back	C	16641
2003-2006	V6 3.5L; Sedan		
	2.5 in. Cat-Back	J	16861

G37			
2008-2012	V6 3.7L; Coupe; Excl. Convertible		
	2.5 in. Cat-Back	C	16820

KIA

FORTE			
2010-2012	L4 2.0L		
	2.25 in. Cat-Back	J	15520

LEXUS

GS300			
1993-1997	6 3.0L		
	2.25 in. Cat-Back	C	16928

IS250			
2006-2011	6 2.5L		
	2.5 in. Cat-Back	C	16764

IS300			
2001-2005	6 3.0L		
	2.5 in. Cat-Back	D	16762

IS350			
2006-2011	8 3.5L		
	2.5 in. Cat-Back	C	16764

SC430			
2002-2008	8 4.3L		
	2.5 in. Cat-Back	C	16917

LINCOLN

LS			
2003-2006	V8 3.9L		
	2.25 in. Cat-Back	C	16678
2003-2005	V6 3.0L		
	2.25 in. Cat-Back	C	16678
2000-2002	V6 3.0L		
	2.25 in. Cat-Back	C	15710
2000-2002	V8 3.9L		
	2.25 in. Cat-Back	C	15710

MKS			
2010-2012	V6 3.5L; Turbocharged		
	2.5 in. Cat-Back	C	15553

MKZ			
2010-2012	V6 3.5L		
	2.25 in. Cat-Back	C	15554
2007-2009	V6 3.5L; FWD		
	2.25 in. Cat-Back	C	16675

ZEPHYR			
2006-2006	V6 3.0L; FWD		
	2.25 in. Cat-Back	C	16675

MASERATI

COUPE			
2003-2007	V8 4.2L		
	2.5 in. Cat-Back	I	16503

GRANSPORT			
2005-2007	V8 4.2L		
	2.5 in. Cat-Back	I	16503

MAZDA

2			
2011-2012	L4 1.5L		
	2.25 in. Cat-Back	H	15555

3			
2010-2012	L4 2.0L		
	2.25 in. Cat-Back	H	15556
2010-2012	L4 2.3L Turbocharged; Mazdaspeed 3		
	2.5,3 in. Cat-Back	C	15557

3			
2010-2012	L4 2.5L		
	2.25,2.5 in. Cat-Back	C	15497
	2.25 in. Cat-Back	H	15556

2007-2009			
	L4 2.0L		
	2.25 in. Cat-Back	H	16786
2007-2009			
	L4 2.3L		
	2.25 in. Cat-Back	H	16786

2007-2009			
	L4 2.3L Turbocharged; Mazdaspeed 3		
	3 in. Cat-Back	H	16821
2004-2006			
	L4 2.0L		
	2.25 in. Cat-Back	H	15861

2004-2006			
	L4 2.3L		
	2.25 in. Cat-Back	H	15861

6			
2006-2007	L4 2.3L; Mazdaspeed 6		
	2.5 in. Cat-Back	C	16609

2003-2006			
	L4 2.3L		
	2.25 in. Cat-Back	C	15803

2003-2006			
	V6 3.0L		
	2.25 in. Cat-Back	C	15802

MIATA/MX5

2006-2012	L4 2.0L		
	2.5 in. Cat-Back	C	16668
2004-2005	L4 1.8L Turbocharged; Mazdaspeed		
	2.5 in. Cat-Back	D	16639

1999-2005			
	L4 1.8L		
	2.5 in. Cat-Back	D	16638

1994-1997			
	L4 1.8L		
	2.25 in. Cat-Back	D	15715

1990-1993			
	L4 1.6L		
	2.25 in. Cat-Back	D	15715

EXIT STYLE CONFIGURATIONS:

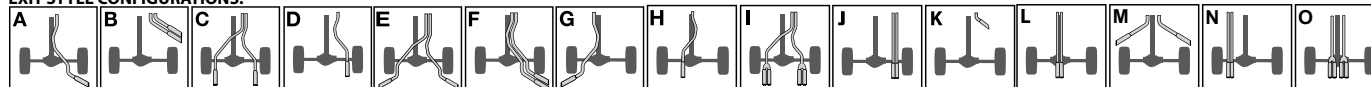

SOME DUAL SYSTEMS ON OPTIONS "C" MAY NEED MODIFICATION TO FIT AROUND TRAILER HITCHES

MAZDA		Exit Style	Part #
PROTEGE			
2003-2003	L4 2.0L		
	2.25 in. Cat-Back	D	15804
2001-2001	L4 2.0L		
	2.25 in. Cat-Back	J	15751
PROTEGES			
2002-2003	L4 2.0L		
	2.25 in. Cat-Back	J	15752
RX-8			
2004-2012	R2 1.3L		
	2.5 in. Cat-Back	C	15823
MERCURY			
GRAND MARQUIS			
2006-2010	V8 4.6L		
	2.25 in. Cat-Back	C	16788
MILAN			
2006-2009	V6 3.0L; FWD		
	2.25 in. Cat-Back	C	16675
MINI			
COOPER			
2007-2011	L4 1.6L Turbocharged; S		
	2.5 in. Cat-Back	L	16815
2004-2006	L4 1.6L Supercharged; S		
	2.25,2.5 in. Cat-Back	L	16662
2002-2006	L4 1.6L		
	2.25 in. Cat-Back	D	15741
2002-2003	L4 1.6L Supercharged; S		
	2.25,2.5 in. Cat-Back	L	15742
COOPER CLUBMAN			
2008-2011	L4 1.6L		
	2.25 in. Cat-Back	D	16854
2008-2011	L4 1.6L Turbocharged; S		
	2.5 in. Cat-Back	C	16855
COUNTRYMAN			
2011-2012	L4 1.6L Turbocharged; S; Incl All4		
	2.5 in. Cat-Back	C	15490
2011-2011	L4 1.6L		
	2.5 in. Cat-Back	C	15548
MITSUBISHI			
ECLIPSE			
2010-2011	V6 3.8L		
	2.5 in. Cat-Back	C	15558
2006-2009	L4 2.4L		
	2.5 in. Cat-Back	D	16667
2006-2008	V6 3.8L; GT; Incl. Spyder		
	2.5 in. Cat-Back RS/GS 50 State	D	16657
2001-2005	L4 2.4L		
	2.25 in. Cat-Back RS/GS 50 State	H	15744
2001-2005	V6 3.0L		
	2.25 in. Cat-Back RS/GS CA only	H	15744
2000-2000	L4 2.4L		
	2.25 in. Cat-Back GT/GTS 49 State	N	15775
2000-2000	V6 3.0L		
	2.25 in. Cat-Back ; Excl AWD 50 State	N	15775
1995-1998	L4 2.0L		
	2.25 in. Cat-Back	H	15691

MITSUBISHI		Exit Style	Part #
LANCER			
2009-2010	L4 2.0L Turbocharged; Ralliart		
	3 in. Cat-Back	C	15597
2008-2011	L4 2.0L Turbocharged; Evolution X		
	3 in. Cat-Back	C	16823
2008-2010	L4 2.0L		
	2.25 in. Cat-Back	D	16822
2003-2007	L4 2.0L Evolution		
	3 in. Cat-Back JDM Style	D	16659
	3 in. Cat-Back	D	16660
2002-2003	L4 2.0L; ES & OZ Models		
	2.25 in. Cat-Back	D	15805
NISSAN			
300ZX			
1990-1995	V6 3.0L Turbocharged		
	0 in. Cat-Back	I	16767
300ZX			
1990-1995	V6 3.0L; Excl. 2+2		
	0 in. Cat-Back	I	16766
350Z			
2003-2009	V6 3.5L		
	2.5 in. Cat-Back	C	15765
	2.5,3.5 in. Cat-Back Dual Mufflers	C	16784
370Z			
2009-2012	V6 3.7L		
	2.5 in. Cat-Back	C	16595
ALTIMA			
2008-2011	L4 2.5L; Coupe		
	2.25 in. Axle-Back	C	16825
2002-2006	L4 2.5L		
	2.5 in. Cat-Back	D	16683
2002-2006	V6 3.5L		
	2.25 in. Cat-Back	C	16682
GT-R			
2010-2012	V6 3.8L Turbocharged		
	3 in. Cat-Back	I	15488
2009-2009	V6 3.8L Turbocharged		
	3 in. Cat-Back	I	16916
SENTRA			
2002-2006	L4 2.5L		
	2.25 in. Cat-Back	J	15764
OLDSMOBILE			
442			
1968-1971	V8 7.5L; 455 CID		
	2.5 in. X-Member-Back	D	15894
	3 in. X-Member-Back	E	15898
1968-1970	V8 5.7L; 350 CID		
	2.5 in. X-Member-Back	D	15894
	3 in. X-Member-Back	E	15898
1968-1969	V8 6.6L; 400 CID		
	2.5 in. X-Member-Back	D	15894
	3 in. X-Member-Back	E	15898
1965-1967	V8 6.6L; 400 CID		
	3 in. X-Member-Back	E	15897
	2.5 in. X-Member-Back	D	15893

EXIT STYLE CONFIGURATIONS:

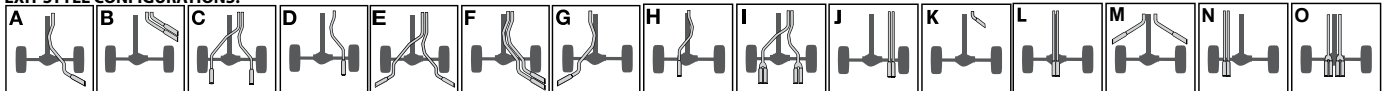

SOME DUAL SYSTEMS ON OPTIONS "C" MAY NEED MODIFICATION TO FIT AROUND TRAILER HITCHES

"MagnaFlow has been our choice for performance exhaust since day one. We love their customer service and the wide variety of systems they offer makes it easy to find a custom fit for any Project we may have." —**Barry's Speed Shop, Corona, CA**



Car Applications

OLDSMOBILE Exit Style Part

CUTLASS			
1970-1973	V8 7.5L; 455 CID		
	2.5 in. X-Member-Back	D	15894
	3 in. X-Member-Back	E	15898
1968-1973	V8 5.7L; 350 CID		
	2.5 in. X-Member-Back	D	15894
	3 in. X-Member-Back	E	15898
1968-1968	V8 6.6L; 400 CID		
	2.5 in. X-Member-Back	D	15894
	3 in. X-Member-Back	E	15898
1965-1967	V8 6.6L; 400 CID		
	3 in. X-Member-Back	E	15897
	2.5 in. X-Member-Back	D	15893
1964-1967	V8 5.4L; 327 CID		
	2.5 in. X-Member-Back	D	15893
	3 in. X-Member-Back	E	15897

OMEGA			
1973-1973	V8 5.7L; 350 CID		
	2.5 in. X-Member-Back	D	16610
	3 in. X-Member-Back	E	16611

PLYMOUTH Exit Style Part

BARRACUDA			
1972-1972	V8 5.6L; 340CID		
	3 in. X-Member-Back	C	15852
	2.5 in. X-Member-Back	C	15851
1970-1972	V8 5.2L; 318CID		
	3 in. X-Member-Back	C	15852
	2.5 in. X-Member-Back	C	15851
1970-1971	V8 6.3L; 383 CID		
	3 in. X-Member-Back	C	15852
	2.5 in. X-Member-Back	C	15851

PONTIAC Exit Style Part

FIREBIRD			
1998-2002	V6 3.8L		
	2.5 in. Cat-Back	C	15693
1998-2002	V8 5.7L		
	2.5,3 in. Cat-Back	C	15684
	2.5,3 in. Cat-Back	I	16723
1995-1997	V6 3.8L		
	2.5 in. Cat-Back	C	15694
1993-1997	V8 5.7L		
	2.5,3 in. Cat-Back	C	15620
1993-1995	V6 3.4L		
	2.5 in. Cat-Back	C	15694
1987-1992	V8 5.7L		
	2.5,3 in. Cat-Back	C	16829
1987-1989	V8 5.7L		
	2.5,3 in. Manifold Pipe Y-pipe Assy.		16450
1986-1989	V8 5.0L		
	2.5,3 in. Manifold Pipe Y-pipe Assy.		16450
1983-1992	V8 5.0L		
	2.5,3 in. Cat-Back	C	16829
1977-1979	V8 4.9L		
	2.5 in. Cat-Back	C	16830
	2,2.5 in. Manifold Pipe Y-pipe Assy.		16447
1977-1979	V8 5.0L		
	2.5 in. Cat-Back	C	16830
	2,2.5 in. Manifold Pipe Y-pipe Assy.		16447
1976-1976	V8 6.6L; 400 CID		
	2.2.5 in. Manifold Pipe Y-pipe Assy.		16448
1975-1979	V8 5.7L; 350 CID		
	2.5 in. Cat-Back	C	16830
	2,2.5 in. Manifold Pipe Y-pipe Assy.		16447
1975-1979	V8 6.6L; 400 CID		
	2.5 in. Cat-Back	C	16830

PONTIAC Exit Style Part

FIREBIRD			
1970-1974	V8 5.7L; 350 CID *		
	2.5 in. Manifold Pipe 3 Bolt Flange; w/ 3.0in. Adaptors		16438
	3 in. X-Member-Back	E	15899
	2.5 in. X-Member-Back	C	16827
1970-1974	V8 7.5L; 455 CID *		
	2.5 in. X-Member-Back	C	16827
	3 in. X-Member-Back	E	15899
	2.5 in. Manifold Pipe 2 Bolt Flange; D-Port; Oval Port; w/ 3.0in. Adaptors		16439
1967-1969	V8 6.6L; 400 CID *		
	2.5 in. X-Member-Back	E	15896
	3 in. X-Member-Back	E	15899
	2.5 in. X-Member-Back	E	15895
	2.5 in. Manifold Pipe 2 Bolt Flange; D-Port; Oval Port; w/ 3.0in. Adaptors		16437
1967-1969	V8 Small Block; 326/350 CID *		
	2.5 in. X-Member-Back	E	15896
	3 in. X-Member-Back	E	15899
	2.5 in. X-Member-Back	E	15895
	2.5 in. Manifold Pipe 2 Bolt Flange; D-Port; Oval Port; w/ 3.0in. Adaptors		16436

G5			
2007-2009	L4 2.2L		
	2.25 in. Cat-Back	H	16618

G6			
2008-2009	V6 3.5L		
	2.5 in. Cat-Back	H	16876

2006-2007			
	L4 2.4L		
	2.5 in. Cat-Back	H	16760

2005-2007			
	V6 3.5L		
	2.5 in. Cat-Back	H	16760

G8			
2009-2009	V8 6.2L; GXP		
	2.5 in. Cat-Back Competition	I	16795
	2.5 in. Axle-Back Street	I	16883
	3 in. Cat-Back Competition	C	16857
	2.5 in. Cat-Back Street	I	16887

2008-2009			
	V6 3.6L		
	2.5 in. Cat-Back	C	15774

2008-2009			
	V8 6.0L; GT		
	2.5 in. Cat-Back Competition	I	16795
	2.5 in. Axle-Back Street	I	16883
	3 in. Cat-Back Competition	C	16857
	2.5 in. Cat-Back Street	I	16887

GRAND PRIX			
2006-2007	V6 3.8L; GT		
	2.5 in. Cat-Back	I	16730
2005-2008	V8 5.3L; GXP		
	2.5 in. Cat-Back	I	16726
1997-2003	V6 3.8L; GT/GTP		
	2.5 in. Cat-Back	I	16731

GTO			
2005-2006	V8 6.0L		
	2.5 in. Cat-Back Street	C	15892
	3 in. Cat-Back Competition	C	16734

2004-2004			
	V8 5.7L		
	2.5 in. Cat-Back	N	15868

1970-1973			
	V8 7.5L; 455 CID		
	2.5 in. X-Member-Back	D	15894
	3 in. X-Member-Back	E	15898

1970-1970			
	V8 5.7L; 350 CID		
	2.5 in. X-Member-Back	D	15894
	3 in. X-Member-Back	E	15898

1968-1973			
	V8 6.6L; 400 CID		
	2.5 in. X-Member-Back	D	15894
	3 in. X-Member-Back	E	15898

1967-1967			
	V8 6.6L; 400 CID		
	3 in. X-Member-Back	E	15897
	2.5 in. X-Member-Back	D	15893

EXIT STYLE CONFIGURATIONS:

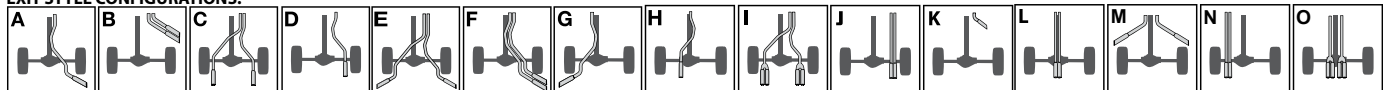

SOME DUAL SYSTEMS ON OPTIONS "C" MAY NEED MODIFICATION TO FIT AROUND TRAILER HITCHES

PONTIAC

Exit Style Part #

GTO

1964-1966	V8 5.3L		
	2.5 in. X-Member-Back	D	15893
	3 in. X-Member-Back	E	15897
1964-1966	V8 6.4L; 389 CID		
	2.5 in. X-Member-Back	D	15893
	3 in. X-Member-Back	E	15897

SOLSTICE

2007-2009	L4 2.0L Turbocharged		
	2.5,3 in. Cat-Back	C	16645
2006-2009	L4 2.4L		
	2.5 in. Cat-Back	D	16646

SUNFIRE

1996-2002	L4 2.4L		
	2.25 in. Cat-Back	N	15761
	2.25 in. Cat-Back	C	15762
1995-2005	L4 2.2L		
	2.25 in. Cat-Back	N	15761
	2.25 in. Cat-Back	C	15762

VENTURA

1972-1973	V8 5.7L; 350 CID		
	2.5 in. X-Member-Back	D	16610
	3 in. X-Member-Back	D	16611
1971-1972	V8 5.0L; 307 CID		
	2.5 in. X-Member-Back	D	16610
	3 in. X-Member-Back	D	16611

VIBE

2009-2009	L4 2.4L; AWD		
	2.25 in. Cat-Back	D	16848
2009-2009	L4 2.4L; FWD, Independent Rear Suspension		
	2.25 in. Cat-Back	D	16849
2003-2008	L4 1.8L		
	2.25 in. Cat-Back	N	15759

SATURN

ION

2004-2007	L4 2.0L		
	2.5 in. Cat-Back	H	16663

SKY

2007-2009	L4 2.0 L; Turbocharged; RedLine		
	2.25 in. Cat-Back Street	I	16664
	2.3 in. Cat-Back Competition	I	16761
2007-2009	L4 2.4L		
	2.25 in. Cat-Back	J	16647

SCION

TC

2011-2012	L4 2.5L		
	2.25 in. Axle-Back	H	15487
2005-2010	L4 2.4L		
	2.25,2.5 in. Cat-Back	D	16640

XA

2003-2007	L4 1.5L		
	2.25 in. Cat-Back	D	16648

XB

2008-2012	L4 2.4L		
	2.25 in. Cat-Back	D	16787
2003-2007	L4 1.5L		
	2.25 in. Cat-Back	D	15822

SCION

Exit Style Part #

XD

2008-2012	L4 1.8L		
	2.25 in. Cat-Back	D	16798

SUBARU

IMPREZA

2011-2011	H4 2.5L Turbocharged; Sedan; WRX STI		
	3 in. Cat-Back Sport	I	15472
	2.5 in. Cat-Back Touring	I	15471
2008-2011	H4 2.5L Turbocharged; Hatchback; STI		
	3 in. Cat-Back	I	16824
2008-2010	H4 2.5L Turbocharged; Hatchback; WRX		
	2.5 in. Cat-Back	D	16847
2008-2010	H4 2.5L Turbocharged; Sedan; WRX		
	2.5 in. Cat-Back	C	16856
2006-2007	H4 2.5L Turbocharged; WRX; STI		
	3 in. Cat-Back	H	16835
2004-2005	H4 2.5L Turbocharged; WRX; STI		
	3 in. Cat-Back JDM Style	D	16658
	2.5 in. Cat-Back	D	16661
2002-2005	H4 2.0L Turbocharged; WRX; STI		
	2.5 in. Cat-Back	D	16661
	3 in. Cat-Back JDM Style	D	16658

LEGACY

2010-2010	L4 2.4L Turbocharged; GT		
	3 in. Cat-Back	C	16377
2005-2009	L4 2.5L Turbocharged; GT		
	2.25,3 in. Cat-Back	C	16747

TOYOTA

CELICA

2000-2005	L4 1.8L; GT		
	2.25 in. Axle-Back	D	15730
2000-2005	L4 1.8L; GTS		
	2.25 in. Axle-Back	D	15812

COROLLA

2003-2006	L4 1.8L		
	2.25 in. Cat-Back	D	15807

MATRIX

2009-2010	L4 2.4L; S Models, AWD		
	2.25 in. Cat-Back	D	16848
2009-2010	L4 2.4L; S, XRS; FWD; Independent Rear Suspension		
	2.25 in. Cat-Back	D	16849
2009-2010	L4 2.4L; S; FWD; Independent Rear Suspension		
	2.25 in. Cat-Back	D	16849
2003-2008	L4 1.8L; FWD		
	2.25 in. Cat-Back	N	15759

YARIS

2007-2011	L4 1.5L; Sedan		
	2.25 in. Cat-Back	H	16844
2006-2011	L4 1.5L; Hatchback		
	3 in. Axle-Back	J	16845

VOLKSWAGEN

BEETLE

2006-2011	L5 2.5L		
	2.5 in. Cat-Back w/o Fascia Cutout	N	16690
2002-2004	L4 1.8L Turbocharged; S Models		
	2.25 in. Cat-Back w/ Fascia Cutout	N	15745
1999-2005	L4 1.8L		
	2.25 in. Cat-Back	N	15648

EXIT STYLE CONFIGURATIONS:

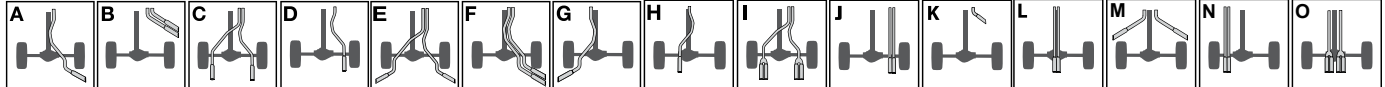

SOME DUAL SYSTEMS ON OPTIONS "C" MAY NEED MODIFICATION TO FIT AROUND TRAILER HITCHES

"I simply love the sound and extra horsepower I'm getting out of my MagnaFlow system. You can't go wrong with that!"
 – Samuel Hübinette, Professional Drift and Stunt Driver



Car Applications

VOLKSWAGEN Exit Style Part #

BEETLE

2012-2012	L4 2.0L Turbocharged		
	Cat-Back	C	15061
1998-2003	L4 2.0L		
	2.25 in. Cat-Back	N	15648

CC

2009-2011	L4 2.0L Turbocharged		
	2.5 in. Cat-Back	N	15559

GOLF

2002-2005	L4 1.8L Turbocharged		
	2.25 in. Cat-Back w/ Fascia Cutout	N	15745
	2.25 in. Cat-Back	N	15648

2002-2005	V6 2.8L		
	2.25 in. Cat-Back	N	16651
	2.25 in. Cat-Back w/ Fascia Cutout	N	15745

2002-2004	L4 1.8L Turbocharged		
	2.25 in. Cat-Back	N	16651

2000-2006	L4 1.8L		
	2.25 in. Cat-Back	N	15648

1999-2011	L4 2.0L		
	2.25 in. Cat-Back	N	15648

1995-1999	V6 2.8L		
	2.25 in. Cat-Back	N	15670

1993-1999	L4 2.0L		
	2.25 in. Cat-Back	N	15670

GTI

2010-2011	L4 2.0L Turbocharged		
	2.5,3 in. Cat-Back	C	15521

2006-2009	L4 2.0L Turbocharged		
	3 in. Cat-Back	N	16691

JETTA

2011-2011	L4 2.0L; S		
	2.5 in. Cat-Back	H	15486

2006-2010	L4 2.0L Turbocharged		
	2.5 in. Cat-Back	N	16693

2005-2010	L5 2.5L		
	2.5 in. Cat-Back	D	16694

2003-2005	L4 1.8L Turbocharged, GLI		
	2.5 in. Cat-Back	H	16652

2002-2005	L4 1.8L Turbocharged		
	2.25 in. Cat-Back w/ Fascia Cutout	N	15746

2002-2004	V6 2.8L		
	2.25 in. Cat-Back w/ Fascia Cutout	N	15746

2000-2003	L4 2.0L		
	2.25 in. Cat-Back	N	15669

2000-2001	L4 1.8L		
	2.25 in. Cat-Back	N	15669

1999-2001	V6 2.8L		
	2.5 in. Cat-Back Sport	N	16768
	2.25 in. Cat-Back Touring	N	15669

1994-1998	V6 2.8L		
	2.25 in. Cat-Back	N	15668

1993-1999	L4 2.0L		
	2.25 in. Cat-Back	N	15668

PASSAT CC

2009-2009	L4 2.0L Turbocharged		
	3 in. Cat-Back	N	16561

PHAETON

2004-2006	V8 4.2L		
	2.5 in. Cat-Back Reuses OEM Fascia-Tip	C	16990

R32

2008-2008	V6 3.2L		
	2.5 in. Cat-Back Sport	L	16502
	2.5 in. Cat-Back Touring	L	16501

2004-2004	V6 3.2L		
	2.5 in. Cat-Back	C	16650

VOLKSWAGEN Exit Style Part #

RABBIT

2006-2010	L5 2.5L		
	2.25 in. Cat-Back	N	16692

VOLVO

C30

2008-2009	L5 2.5L Turbocharged		
	2.5 in. Cat-Back	C	16479

EXIT STYLE CONFIGURATIONS:

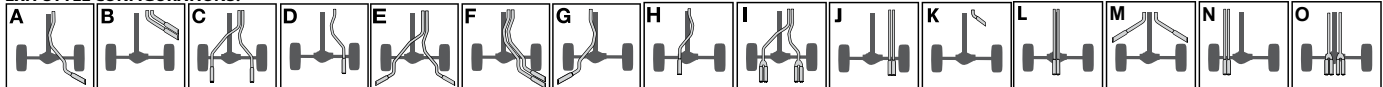

SOME DUAL SYSTEMS ON OPTIONS "C" MAY NEED MODIFICATION TO FIT AROUND TRAILER HITCHES

Team

MAGNAFLOW



LIKE US!

FACEBOOK.COM/MAGNAFLOW

JOIN OUR TEAM

&

WIN V.I.P. EXPERIENCES

TRUCK • SUV

Exit Configurations

MagnaFlow's truck applications offer the customer systems with multiple options to meet just about every exit configuration imaginable:

Single Side Exit — Near stock exit point with the most sound control. Best suited to towing hauling and cruising.

Dual Split Rear Exit — Adjustable exit points under the bumper suited for most OEM hitches with an aggressive exhaust note and additional flow capacity for a few more horsepower.

Dual Side Exit Before Rear Tire — The most aggressive exhaust note and reduced weight for the customer seeking the highest performance and a truly aggressive tone.

Dual Side Exit Behind Rear Tire — Similar performance and sound character as the Dual Split Rear Exit with a unique same side configuration without issues from OEM or aftermarket hitches or roll pans.

EXIT STYLE CONFIGURATIONS:

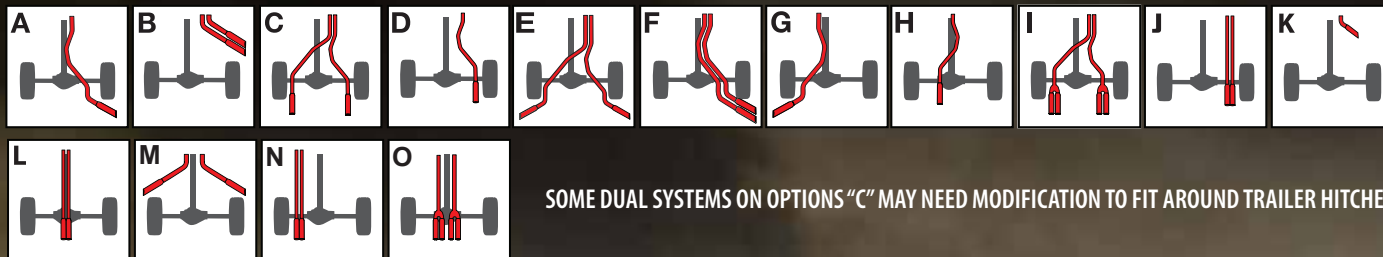

SOME DUAL SYSTEMS ON OPTIONS "C" MAY NEED MODIFICATION TO FIT AROUND TRAILER HITCHES



SAMUEL HUBINETTE
TORC Series Racer

JV • DIESEL

D.P.F. = Diesel Particulate Filter (07-12)



MAGNAFLOW PERFORMANCE Diesel systems are our premium line which includes mandrel-bent stainless steel tubing, a mirror finish 100% stainless steel muffler, an optional muffler delete pipe, band clamps, and polished MagnaFlow single-wall inter-cooled tip(s).



MAGNAFLOW PERFORMANCE Diesel systems are our premium line which includes mandrel-bent stainless steel tubing, a satin finish 100% stainless steel muffler, an optional muffler delete pipe, band clamps, and polished MagnaFlow single-wall inter-cooled tip(s).



MAGNAFLOW PRO PERFORMANCE is our entry-level performance line which includes mandrel-bent stainless steel tubing, a muffler delete pipe, saddle clamps, and polished MagnaFlow single-wall inter-cooled tip(s).

O.R.P.S. = Off Road Pro Series



MAGNAFLOW OFF ROAD PRO-SERIES Turn down before the axle design provides an aggressive exhaust note and allows for use on vehicles with highly modified suspension systems. Lifted, lowered, air bagged or long travel.

Non D.P.F. Equipped (94-07)



MAGNAFLOW PERFORMANCE Diesel systems are our premium line featuring a POLISHED 100% stainless steel muffler and mandrel-bent stainless steel tubing with a DOUBLE WALL tip(s).



MAGNAFLOW XL PERFORMANCE is our mid-level performance Diesel system featuring a 100% stainless steel muffler and mandrel-bent stainless steel tubing with a single wall tip(s).



MAGNAFLOW PRO PERFORMANCE is our entry-level performance Diesel system featuring a 100% stainless steel muffler and mandrel-bent stainless steel tubing. Optional 5" diesel tips are sold separately.



MAGNAFLOW DIRECT-FIT MUFFLER KIT. If you want to get some of the sound, looks and performance of our full cat-back systems, but are working on a budget, consider MagnaFlow's all new 100% stainless steel direct-fit muffler kit.



DENNIS ANDERSON
Grave Digger

Truck Applications

AM GENERAL

Year	Model	Exit Style	Series	Part #
1995-1998	V8 6.5L ; Excl. Turbocharged			
	3 in. Cat-Back	A		16504

AUDI TRUCK

Year	Model	Exit Style	Series	Part #
2007-2007	V8 4.2L			
	2.5 in. Cat-Back	C		15085

CADILLAC TRUCK

ESCALADE

Year	Model	Exit Style	Series	Part #
2010-2012	V8 6.2L			
	3.5 in. Cat-Back	D		15626
2009-2009	V8 6.2L; Excl. Hybrid			
	3.5 in. Cat-Back	D		16589
2007-2008	V8 6.2L; Excl. Hybrid			
	3.5 in. Cat-Back	A		16671
2002-2006	V8 6.0L			
	2.5,3.5 in. Cat-Back	A		15734
2002-2005	V8 5.3L			
	3 in. Cat-Back	A		15666

ESCALADE- ESV/EXT

Year	Model	Exit Style	Series	Part #
2010-2012	V8 6.2L; ESV; EXT			
	3.5 in. Cat-Back	D		15627
2009-2009	V8 6.2L; ESV; EXT			
	3.5 in. Cat-Back	D		16590
2007-2008	V8 6.2L; ESV; EXT			
	3.5 in. Cat-Back	D		16720
2003-2006	V8 6.0L; ESV; EXT			
	2.5,3 in. Cat-Back	A		15837

CHEVROLET DIESEL

DURAMAX, 4in. SINGLE

Year	Model	Exit Style	Series	Part #
2011-2012	V8 6.6L; Silverado 2500HD/3500; Extended-Crew Cab/Short-Long Bed			
	4 in. DPF-Back	A	Pro	17908
2007-2010	V8 6.6L; Silverado 2500HD/3500; Extended-Crew Cab/Short-Long Bed			
	4 in. DPF-Back	A	MagnaFlow	16910
	4 in. DPF-Back	A	XL	16911
	4 in. DPF-Back	A	Pro	17911
2006-2007	V8 6.6L; Silverado 2500HD/3500; Extended Cab/Short Bed (78in. Bed)			
	4 in. Cat-Back	A	Pro	17964
	4 in. Turbo-Back	A	Pro	17960
2006-2007	V8 6.6L; Silverado 2500HD/3500; Crew Cab/Short Bed (78in. Bed)			
	4 in. Cat-Back	A	MagnaFlow	16942
	4 in. Cat-Back	A	XL	16943
	4 in. Cat-Back	A	Pro	17943
2006-2007	V8 6.6L; Silverado 2500HD/3500; Extended Cab/Long Bed (96in. Bed)			
	4 in. Cat-Back	A	MagnaFlow	16944
	4 in. Cat-Back	A	XL	16945
	4 in. Cat-Back	A	Pro	17945
2006-2007	V8 6.6L; Silverado 3500; Crew Cab/ Long Bed (96in. Bed) Dually			
	4 in. Cat-Back	A	MagnaFlow	16940
	4 in. Cat-Back	A	XL	16941
	4 in. Cat-Back	A	Pro	17941
2003-2005	V8 6.6L; Silverado 2500HD/3500; Extended Cab/Short Bed (78in. Bed)			
	4 in. Turbo-Back	A	Pro	17934
	4 in. Cat-Back	A	Pro	17937
2001-2007	V8 6.6L; Silverado 2500HD/3500; Crew Cab/Long Bed (96in. Bed)			
	4 in. Cat-Back	K	Off-Road Pro	17130
	4 in. Turbo-Back	K	Off-Road Pro	17129
2001-2007	V8 6.6L; Silverado 2500HD/3500; Crew Cab/Short Bed (78in. Bed)			
	4 in. Turbo-Back	A	MagnaFlow	16900
	4 in. Turbo-Back	A	XL	16902
2001-2007	V8 6.6L; Silverado 2500HD/3500; Crew Cab/Short Bed (78in. Bed)			
	4 in. Turbo-Back	A	Pro	17902
	4 in. Cat-Back	K	Off-Road Pro	17128
	4 in. Turbo-Back	K	Off-Road Pro	17127

CHEVROLET DIESEL

DURAMAX, 4in. SINGLE

Year	Model	Exit Style	Series	Part #
2001-2005	V8 6.6L; Silverado 2500HD/3500; Crew Cab/Short Bed (78in. Bed)			
	4 in. Cat-Back	A	MagnaFlow	16932
	4 in. Cat-Back	A	XL	16933
	4 in. Cat-Back	A	Pro	17933
2001-2005	V8 6.6L; Silverado 2500HD/3500; Extended Cab/Long Bed (96in. Bed)			
	4 in. Cat-Back	A	MagnaFlow	16934
	4 in. Cat-Back	A	XL	16935
	4 in. Cat-Back	A	Pro	17935
2001-2005	V8 6.6L; Silverado 3500; Crew Cab/ Long Bed (96in. Bed) Dually			
	4 in. Cat-Back	A	MagnaFlow	16930
	4 in. Cat-Back	A	XL	16931
	4 in. Cat-Back	A	Pro	17931
	4 in. Cat-Back	K	Off-Road Pro	17130
2001-2002	V8 6.6L; Silverado 2500HD/3500; Extended Cab/Short Bed (78in. Bed)			
	4 in. Cat-Back	A	Pro	17942
	4 in. Turbo-Back	A	Pro	17939

DURAMAX, 5in. SINGLE

Year	Model	Exit Style	Series	Part #
2011-2012	V8 6.6L; Silverado 2500HD/3500; Extended-Crew Cab/Short-Long Bed			
	5 in. DPF-Back	A	Pro	17910
2007-2010	V8 6.6L; Silverado 2500HD/3500; Extended-Crew Cab/Short-Long Bed			
	5 in. DPF-Back	A	MagnaFlow	16912
	5 in. DPF-Back	A	XL	16913
	5 in. DPF-Back	A	Pro	17913
2006-2007	V8 6.6L; Silverado 2500HD/3500; Extended Cab/Short Bed (78in. Bed)			
	5 in. Turbo-Back	A	Pro	17962
	5 in. Cat-Back	A	Pro	17966
2006-2007	V8 6.6L; Silverado 2500HD/3500; Crew Cab/Long Bed (96in. Bed)			
	5 in. Cat-Back	A	MagnaFlow	16962
	5 in. Cat-Back	A	XL	16963
	5 in. Cat-Back	A	Pro	17963
2006-2007	V8 6.6L; Silverado 2500HD/3500; Crew Cab/Short Bed (78in. Bed)			
	5 in. Cat-Back	A	MagnaFlow	16960
	5 in. Cat-Back	A	XL	16961
	5 in. Cat-Back	A	Pro	17961
2003-2005	V8 6.6L; Silverado 2500HD/3500; Extended Cab/Short Bed (78in. Bed)			
	5 in. Turbo-Back	A	Pro	17936
	5 in. Cat-Back	A	Pro	17938
2001-2007	V8 6.6L; Silverado 2500HD/3500; Crew Cab/Short Bed (78in. Bed)			
	5 in. Turbo-Back	A	MagnaFlow	16908
2001-2007	V8 6.6L; Silverado 2500HD/3500; Crew Cab/Short Bed (78in. Bed)			
	5 in. Turbo-Back	A	XL	16909
	5 in. Turbo-Back	A	Pro	17909
2001-2002	V8 6.6L; Silverado 2500HD/3500; Extended Cab/Short Bed (78in. Bed)			
	5 in. Turbo-Back	A	Pro	17940
	5 in. Cat-Back	A	Pro	17944

DURAMAX, DUAL

Year	Model	Exit Style	Series	Part #
2007-2010	V8 6.6L; Silverado 2500HD/3500; Extended-Crew Cab/Short-Long Bed			
	3.5,4 in. DPF-Back	F	MagnaFlow	16914
2007-2010	V8 6.6L; Silverado 2500HD/3500; Extended-Crew Cab/Short-Long Bed			
	4 in. Cat-Back	E	MagnaFlow	16964
	4 in. Cat-Back	E	XL	16965
	3.5,4 in. DPF-Back	F	XL	16915
	4 in. Cat-Back	E	Pro	17965
	3.5,4 in. DPF-Back	F	Pro	17915
2001-2007	V8 6.6L; Silverado 2500HD/3500; Crew Cab/Short Bed (78in. Bed)			
	4 in. Turbo-Back	E	MagnaFlow	16901
	4 in. Turbo-Back	E	XL	16903
	4 in. Turbo-Back	E	Pro	17903

DURAMAX, D-FIT MUFFLER KIT

Year	Model	Exit Style	Series	Part #
2003-2007	V8 6.6L; Silverado 2500HD/3500; Crew Cab/Long Bed (96in. Bed)			
	3.5 in. D-Fit		D-Fit	16999
2003-2007	V8 6.6L; Silverado 2500HD/3500; Crew Cab/Short Bed (78in. Bed)			
	3.5 in. D-Fit		D-Fit	16999

EXIT STYLE CONFIGURATIONS:

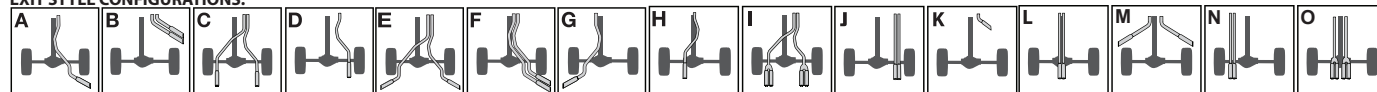

SOME DUAL SYSTEMS ON OPTIONS "C" MAY NEED MODIFICATION TO FIT AROUND TRAILER HITCHES

CHEVROLET DIESEL Exit Style Series Part #

DURAMAX, D-FIT MUFFLER KIT
 2003-2007 V8 6.6L; Silverado 2500HD/3500; Extended Cab/Long Bed (96in. Bed)
 3.5 in. D-Fit D-Fit 16999

CHEVROLET TRUCK

AVALANCHE 1500
 2010-2012 V8 5.3L
 3 in. Cat-Back A 15561

2009-2009 V8 5.3L
 3 in. Cat-Back A 16562

2007-2008 V8 5.3L
 3 in. Cat-Back A 16721

2002-2006 V8 5.3L
 3 in. Cat-Back A 15724

AVALANCHE 2500
 2002-2006 V8 8.1L
 3 in. Cat-Back A 15836

C10 PICKUP
 1966-1972 V8 ALL Models; W/ Rear Coil Springs
 2.5 in. X-Member-Back C 16643

C1500
 1996-1998 V8 5.7L; Extended Cab; (78in. Bed)
 2.5 in. Cat-Back C 15750
 2.5,3.5 in. Cat-Back A 15602

C1500 SUBURBAN
 1996-1999 V8 5.7L
 2.5,3.5 in. Cat-Back A 15699
 3 in. Cat-Back A 15700

C20 PICKUP
 1966-1972 V8 ALL Models; W/ Rear Coil Springs
 2.5 in. X-Member-Back C 16643

C2500 SUBURBAN
 1996-1999 V8 5.7L
 2.5,3.5 in. Cat-Back A 15699
 3 in. Cat-Back A 15700

COLORADO
 2011-2012 V8 5.3L; Extended.-Crew Cab/Short Bed (61.1in Bed)
 2.5,3 in. Cat-Back C 15511
 3 in. Cat-Back A 15509

2009-2010 V8 5.3L; Extended.-Crew Cab/Short Bed (61.1in Bed)
 3 in. Cat-Back A 15625

2007-2012 L5 3.7L Standard Cab; Excl. Sport Suspension
 2.25,2.5 in. Cat-Back C Remove Spare Tire 15846
 2.5 in. Cat-Back A 15844

2007-2012 L5 3.7L Extended.-Crew Cab; Excl. Sport Suspension
 2.25,2.5 in. Cat-Back C Remove Spare Tire 15847
 2.5 in. Cat-Back A 15845

2007-2012 L5 3.7L Extended.-Crew Cab; Excl. Sport Suspension
 2.5 in. Cat-Back A 15845

2004-2006 L5 3.5L Standard Cab; Excl. Sport Suspension
 2.25,2.5 in. Cat-Back C Remove Spare Tire 15846
 2.5 in. Cat-Back A 15844

2004-2006 L5 3.5L Extended.-Crew Cab; Excl. Sport Suspension
 2.25,2.5 in. Cat-Back C Remove Spare Tire 15847
 2.5 in. Cat-Back A 15845

2007-2011 L4 2.9L, Standard Cab; Excl. Sport Suspension
 2.25,2.5 in. Cat-Back C Remove Spare Tire 15846

CHEVROLET TRUCK Exit Style Series Part #

COLORADO
 2007-2011 L4 2.9L, Standard Cab; Excl. Sport Suspension
 2.5 in. Cat-Back A 15844

2007-2011 L4 2.9L; Extended.-Crew Cab; Excl. Sport Suspension
 2.25,2.5 in. Cat-Back C Remove Spare Tire 15847
 2.5 in. Cat-Back A 15845

2004-2006 L4 2.8L, Standard Cab; Excl. Sport Suspension
 2.25,2.5 in. Cat-Back C Remove Spare Tire 15846
 2.5 in. Cat-Back A 15844

2004-2006 L4 2.8L; Extended.-Crew Cab; Excl. Sport Suspension
 2.25,2.5 in. Cat-Back C Remove Spare Tire 15847
 2.5 in. Cat-Back A 15845

EL CAMINO
 1970-1973 V8 7.4L
 2.5 in. X-Member-Back Options 15894
 3 in. X-Member-Back E 15898

1970-1972 V8 6.6L
 2.5 in. X-Member-Back Options 15894
 3 in. X-Member-Back E 15898

1969-1973 V8 5.7L
 2.5 in. X-Member-Back Options 15894
 3 in. X-Member-Back E 15898

1968-1973 V8 5.0L
 2.5 in. X-Member-Back Options 15894
 3 in. X-Member-Back E 15898

1968-1970 V8 6.5L
 2.5 in. X-Member-Back Options 15894
 3 in. X-Member-Back E 15898

1968-1968 V8 5.4L
 3 in. X-Member-Back E 15898
 2.5 in. X-Member-Back Options 15894

1966-1967 V8 6.5L
 3 in. X-Member-Back E 15897
 2.5 in. X-Member-Back Options 15893

1964-1967 V8 4.6L
 2.5 in. X-Member-Back Options 15893
 3 in. X-Member-Back E 15897

1964-1967 V8 5.4L
 3 in. X-Member-Back E 15897
 2.5 in. X-Member-Back Options 15893

K1500
 1996-1998 V8 5.7L; Extended Cab; (78in. Bed)
 2.5 in. Cat-Back C 15750
 2.5,3.5 in. Cat-Back A 15602

K1500 SUBURBAN
 1996-1999 V8 5.7L
 2.5,3.5 in. Cat-Back A 15699
 3 in. Cat-Back A 15700

K2500 SUBURBAN
 1996-1999 V8 5.7L
 2.5,3.5 in. Cat-Back A 15699
 3 in. Cat-Back A 15700

S10
 2001-2004 V6 4.3L; Crew Cab (55.2in. Bed); ZR5
 2.5 in. Cat-Back A 15825

EXIT STYLE CONFIGURATIONS:

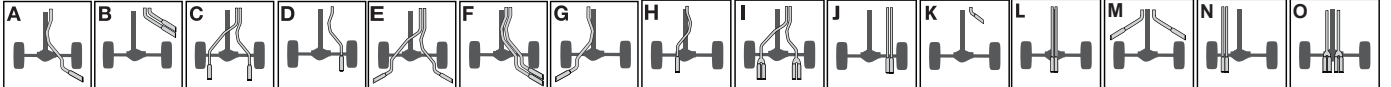

SOME DUAL SYSTEMS ON OPTIONS "C" MAY NEED MODIFICATION TO FIT AROUND TRAILER HITCHES

“MagnaFlow’s product is the only part on my truck that I’ve never broken. I like running MagnaFlow on my truck cause it’s got great sound, awesome performance and is tough as nails. That MagnaFlow hangs in there for the ride and it’s there for the next one. I run it on the Grave Digger and I also run it on my personal truck.” – **Dennis Anderson, Driver of Grave Digger Monster Truck**



Truck Applications

CHEVROLET TRUCK

	Exit Style	Series	Part #
S10			
2000-2003	V6 4.3L; Extended Cab; (73.1in. Bed); Excl. ZR2		
	2.5 in. Cat-Back	C	15796
	2.5 in. Cat-Back	A	15661
1998-2003	L4 2.2L; Extended Cab; (73.1in. Bed)		
	2.25 in. Cat-Back	A	15662
1998-2003	L4 2.2L; Standard Cab; (73.1in. Bed)		
	2.25 in. Cat-Back	A	15706
1998-1999	V6 4.8L; Extended Cab; (73.1in. Bed); 2WD		
	2.5 in. Cat-Back	C	15776
	2.5 in. Cat-Back	A	15777

SILVERADO 1500

2010-2011	V8 4.8L; Crew Cab/Short Bed (69.3in Bed)		
	3 in. Cat-Back	A	15564
	2.5,3 in. Cat-Back	B	15566
	2.5,3 in. Cat-Back	C	15565
2010-2011	V8 4.8L; Extended Cab/Short Bed (78.7in Bed)		
	3 in. Cat-Back	A	15564
	2.5,3 in. Cat-Back	B	15566
	2.5,3 in. Cat-Back	C	15565
2010-2011	V8 4.8L; Standard Cab/Short Bed (78.7in. Bed)		
	3 in. Cat-Back	C	15563
	3 in. Cat-Back	A	15562
2010-2011	V8 5.3L; Crew Cab/Short Bed (69.3in Bed)		
	3 in. Cat-Back	A	15564
	2.5,3 in. Cat-Back	B	15566
	2.5,3 in. Cat-Back	C	15565
2010-2011	V8 5.3L; Extended Cab/Short Bed (78.7in Bed)		
	3 in. Cat-Back	A	15564
	2.5,3 in. Cat-Back	B	15566
	2.5,3 in. Cat-Back	C	15565
2010-2011	V8 5.3L; Standard Cab/Short Bed (78.7in. Bed)		
	3 in. Cat-Back	C	15563
	3 in. Cat-Back	A	15562
2010-2010	V6 4.3L; Standard Cab/Short Bed (78.7in. Bed)		
	3 in. Cat-Back	C	15563
	3 in. Cat-Back	A	15562
2010-2010	V8 6.0L; Crew Cab/Short Bed (69.3in Bed); Hybrid		
	3 in. Cat-Back	C	15568
	3 in. Cat-Back	A	15567
2009-2011	V8 4.8L; Extended-Crew Cab		
	3 in. Cat-Back	K	Off-Road Pro 17102
2009-2011	V8 4.8L; Standard Cab		
	3 in. Cat-Back	K	Off-Road Pro 17101
2009-2011	V8 5.3L; Extended-Crew Cab		
	3 in. Cat-Back	K	Off-Road Pro 17102
2009-2011	V8 5.3L; Standard Cab		
	3 in. Cat-Back	K	Off-Road Pro 17101
2009-2010	V6 4.3L; Extended-Crew Cab		
	3 in. Cat-Back	K	Off-Road Pro 17102
2009-2010	V6 4.3L; Standard Cab		
	3 in. Cat-Back	K	Off-Road Pro 17101
2009-2009	V8 4.8L, Crew/Extended Cab, Short Bed, excl Hybrid		
	3,2.5 in. Cat-Back	C	16568
	3 in. Cat-Back	B	16569
	3 in. Cat-Back	A	16567
2009-2009	V8 5.3L, Crew/Extended Cab, Short Bed, excl Hybrid		
	3,2.5 in. Cat-Back	C	16568
	3 in. Cat-Back	B	16569
	3 in. Cat-Back	A	16567
2009-2009	V8 6.0L, Crew/Extended Cab, Short Bed, excl Hybrid		
	3,2.5 in. Cat-Back	C	16568
	3 in. Cat-Back	B	16569
	3 in. Cat-Back	A	16567

CHEVROLET TRUCK

	Exit Style	Series	Part #
SILVERADO 1500			
2009-2009	V6 4.3L, Standard Cab, Short Bed		
	3 in. Cat-Back	A	16565
	2.5,3 in. Cat-Back	C	16566
2009-2009	V8 4.8L, Standard Cab, Short Bed		
	3 in. Cat-Back	A	16565
	2.5,3 in. Cat-Back	C	16566
2009-2009	V8 5.3L, Standard Cab, Short Bed		
	3 in. Cat-Back	A	16565
	2.5,3 in. Cat-Back	C	16566
2007-2008	V6 4.3L, Standard Cab, Short Bed		
	2.5,3 in. Cat-Back	C	16743
	3 in. Cat-Back	A	16742
2007-2008	V8 4.8L, Standard Cab, Short Bed		
	2.5,3 in. Cat-Back	C	16743
	3 in. Cat-Back	A	16742
2007-2008	V8 5.3L, Standard Cab, Short Bed		
	2.5,3 in. Cat-Back	C	16743
	3 in. Cat-Back	A	16742
2007-2008	V6 4.3L; Extended-Crew Cab		
	3 in. Cat-Back	K	Off-Road Pro 17104
2007-2008	V6 4.3L; Standard Cab		
	3 in. Cat-Back	K	Off-Road Pro 17103
2007-2008	V8 4.8L, Crew/Extended Cab, Short Bed, excl Hybrid		
	3 in. Cat-Back	A	16740
	3,2.5 in. Cat-Back	B	16746
	2.5,3 in. Cat-Back	C	16741
2007-2008	V8 5.3L, Crew/Extended Cab, Short Bed, excl Hybrid		
	3 in. Cat-Back	A	16740
	3,2.5 in. Cat-Back	B	16746
	2.5,3 in. Cat-Back	C	16741
2007-2008	V8 6.0L, Crew/Extended Cab, Short Bed, excl Hybrid		
	3 in. Cat-Back	A	16740
	3,2.5 in. Cat-Back	B	16746
	2.5,3 in. Cat-Back	C	16741
2007-2008	V8 4.8L; Extended-Crew Cab		
	3 in. Cat-Back	K	Off-Road Pro 17104
2007-2008	V8 4.8L; Standard Cab		
	3 in. Cat-Back	K	Off-Road Pro 17103
2007-2008	V8 5.3L; Extended-Crew Cab		
	3 in. Cat-Back	K	Off-Road Pro 17104
2007-2008	V8 5.3L; Standard Cab		
	3 in. Cat-Back	K	Off-Road Pro 17103
2007-2007	V8 4.8L, Classic; Crew Cab/Short Bed (68.4in. Bed)		
	3 in. Cat-Back	D	15839
	2.5,3 in. Cat-Back	C	15841
2007-2007	V8 5.3L; Classic; Crew Cab/Short Bed (68.4in. Bed)		
	3 in. Cat-Back	D	15839
	2.5,3 in. Cat-Back	C	15841
2006-2006	V8 6.0L; Extended Cab (78in. Bed)		
	2.5,3 in. Cat-Back	D	15838
	2.5 in. Cat-Back	C	15840
2004-2006	V8 5.3L; Crew Cab (68.4in. Bed)		
	3 in. Cat-Back	D	15839
	2.5,3 in. Cat-Back	C	15841
2003-2007	V6, 4.3L, Classic Extended Cab Short Bed		
	2.5,3 in. Cat-Back	B	15842
	3 in. Cat-Back	A	15778
2003-2007	V8, 4.8L, Classic Extended Cab Short Bed		
	2.5,3 in. Cat-Back	B	15842
	3 in. Cat-Back	A	15778
2003-2007	V8, 5.3L, Classic Extended Cab Short Bed		
	2.5,3 in. Cat-Back	B	15842
	3 in. Cat-Back	A	15778
2003-2007	V6, 4.3L, Classic Standard Cab Short Bed		
	2.5,3 in. Cat-Back	C	15794

EXIT STYLE CONFIGURATIONS:

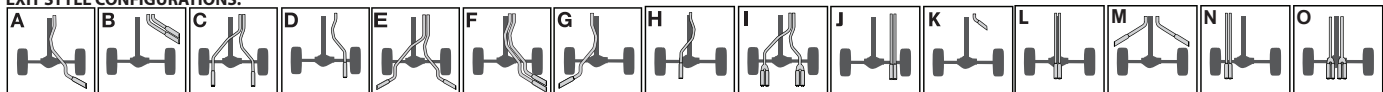

SOME DUAL SYSTEMS ON OPTIONS "C" MAY NEED MODIFICATION TO FIT AROUND TRAILER HITCHES

CHEVROLET TRUCK

	Exit Style	Series	Part #
SILVERADO 1500			
2003-2007	V8, 4.8L, Classic Standard Cab Short Bed		
	2.5,3 in. Cat-Back	C	15794
2003-2007	V8, 5.3L, Classic Standard Cab Short Bed		
	2.5,3 in. Cat-Back	C	15794
2003-2007	V6, 4.3L, Classic Extended Cab Short Bed		
	2.5,3 in. Cat-Back	C	15792
2003-2007	V8, 4.8L, Classic Extended Cab Short Bed		
	2.5,3 in. Cat-Back	C	15792
2003-2007	V8, 5.3L, Classic Extended Cab Short Bed		
	2.5,3 in. Cat-Back	C	15792
2003-2007	V6, 4.3L, Classic Standard Cab Short Bed		
	3 in. Cat-Back	A	15818
2003-2007	V8, 4.8L, Classic Standard Cab Short Bed		
	3 in. Cat-Back	A	15818
2003-2007	V8, 5.3L, Classic Standard Cab Short Bed		
	3 in. Cat-Back	A	15818
1999-2002	V6, 4.3L, Extended Cab, Short Bed		
	3 in. Cat-Back	A	15618
	2.5,3 in. Cat-Back	C	15754
1999-2002	V8, 4.8L, Extended Cab, Short Bed		
	3 in. Cat-Back	A	15618
	2.5,3 in. Cat-Back	C	15754
1999-2002	V8, 5.3L, Extended Cab, Short Bed		
	3 in. Cat-Back	A	15618
	2.5,3 in. Cat-Back	C	15754
1999-2002	V6, 4.3L, Standard Cab, Short Bed		
	2.5,3 in. Cat-Back	C	15753
	3 in. Cat-Back	A	15617
1999-2002	V8, 4.8L, Standard Cab, Short Bed		
	2.5,3 in. Cat-Back	C	15753
	3 in. Cat-Back	A	15617
1999-2002	V8, 5.3L, Standard Cab, Short Bed		
	2.5,3 in. Cat-Back	C	15753
	3 in. Cat-Back	A	15617
SILVERADO 1500 HD			
2007-2007	V8 6.0L; Classic HD; Crew Cab/Short Bed		
	3,4 in. Cat-Back	A	15782
	2.5,3 in. Cat-Back	C	15828
2003-2006	V8 6.0L; Crew Cab/Short Bed		
	3,4 in. Cat-Back	A	15782
	2.5,3 in. Cat-Back	C	15828
2001-2002	V8 6.0L; Extended Cab/Short Bed		
	3,4 in. Cat-Back	A	15728
SILVERADO 2500			
2001-2002	V8 6.0L; Extended Cab (96in. Bed)		
	3,4 in. Cat-Back	A	15780
SILVERADO 2500 HD			
2007-2008	V8 6.0L; Crew Cab/Long Bed (97.6in Bed)		
	3.5,4 in. Cat-Back	A	16789
2007-2008	V8 6.0L; Crew Cab/Long Bed (97.6in Bed)		
	3,3.5 in. Cat-Back	C	16790
2007-2007	V8 6.0L; Classic HD; Crew Cab/Short Bed (78in. Bed)		
	3,4 in. Cat-Back	A	15789
	2.5,3 in. Cat-Back	C	15829

CHEVROLET TRUCK

	Exit Style	Series	Part #
SILVERADO 2500 HD			
2003-2006	V8 6.0L; Crew Cab/Short Bed (78in. Bed)		
	3,4 in. Cat-Back	A	15789
	2.5,3 in. Cat-Back	C	15829
2001-2002	V8 6.0L; Crew Cab/Short Bed (78in. Bed)		
	3,4 in. Cat-Back	A	15732
2001-2002	V8 8.1L; Extended Cab/Long Bed (96in. Bed)		
	3,4 in. Cat-Back	A	15779
SILVERADO SS			
2007-2007	V8 6.0L; Classic; Extended Cab/ Short Bed (78in. Bed)		
	2.5,3 in. Cat-Back	A	15838
	2.5 in. Cat-Back	C	15840
2003-2006	V8 6.0L; Extended Cab/Short Bed (78.7in Bed)		
	2.5,3 in. Cat-Back	A	15838
	2.5 in. Cat-Back	C	15840
SSR			
2005-2006	V8 6.0L		
	2.5,3 in. Cat-Back	C	15843
2003-2004	V8 5.3L		
	2.5,3 in. Cat-Back	C	15843
SUBURBAN 1500			
2009-2011	V8 5.3L		
	3 in. Cat-Back	A	15569
2007-2008	V8 5.3L		
	3 in. Cat-Back	A	16722
2002-2006	V8 5.3L; Excl. Z71		
	3 in. Cat-Back	A	15665
SUBURBAN 2500			
2009-2011	V8 6.0L		
	3 in. Cat-Back	A	15570
2007-2008	V8 6.0L		
	2.5,3 in. Cat-Back	A	16725
2001-2006	V8 8.1L		
	3,4 in. Cat-Back	A	15716
2000-2006	V8 6.0L		
	3,4 in. Cat-Back	A	15798
TAHOE			
2010-2011	V8 5.3L		
	3 in. Cat-Back	A	15571
2009-2009	V8 4.8L		
	3 in. Cat-Back	A	16564
2009-2009	V8 5.3L		
	3 in. Cat-Back	A	16564
2007-2008	V8 4.8L		
	3 in. Cat-Back	A	16672
2007-2008	V8 5.3L; Excl. Hybrid		
	3 in. Cat-Back	A	16672
2000-2006	V8 4.8L; Excl. Z71		
	3 in. Cat-Back	A	15666
2000-2006	V8 5.3L; Excl. Z71		
	3 in. Cat-Back	A	15666
1996-1999	V8 5.7L; 4-Door		
	2.5,3 in. Cat-Back	A	15701
	3 in. Cat-Back	A	15702

EXIT STYLE CONFIGURATIONS:

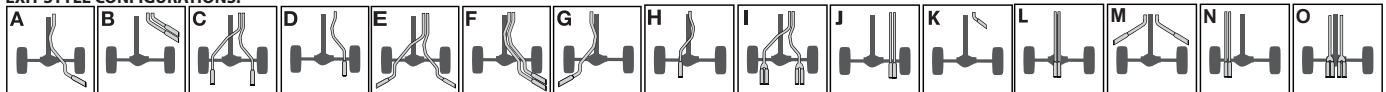

SOME DUAL SYSTEMS ON OPTIONS "C" MAY NEED MODIFICATION TO FIT AROUND TRAILER HITCHES

“My first experiences with a MagnaFlow exhaust system were a championship and world championship. Not only do I have the best sounding truck on the track but I also have the biggest power advantage with my MagnaFlow system.” – **Casey Currie, TORC Series Champion, Pro Lite Driver**



Truck Applications

CHEVROLET TRUCK

	Exit Style	Series	Part #
TRAILBLAZER			
2006-2008 V8 6.0L; SS			
3 in. Cat-Back	D		16656
2002-2010 L6 4.2L; W/ 113in WB			
2.25,3 in. Cat-Back	C		16833

CHRYSLER TRUCK

ASPEN

2007-2009 V8 5.7L Hemi			
3 in. Cat-Back	D		16779

DODGE DIESEL

CUMMINS, 4in. SINGLE

2011-2011 L6 6.7L; Ram 2500HD/3500; Crew-Mega Cab/Short-Long Bed			
4 in. DPF-Back	A	MagnaFlow	16382
4 in. DPF-Back	A	XL	16383
4 in. DPF-Back	A	Pro	17917
2007-2010 L6 6.7L; Ram 2500HD/3500; Crew-Mega Cab/Short-Long Bed			
4 in. DPF-Back	A	MagnaFlow	16973
4 in. DPF-Back	A	XL	16970
4 in. DPF-Back	A	Pro	17970
2004-2007 L6 5.9L; Ram 2500HD/3500; Crew-Mega Cab/Short-Long Bed			
4 in. Turbo-Back	K	Off-Road Pro	17131
4 in. Cat-Back	K	Off-Road Pro	17132
2003-2004 L6 5.9L ; Ram 2500HD/3500; Crew Cab/Long Bed (96 in. Bed)			
4 in. Cat-Back	A	MagnaFlow	15957
4 in. Turbo-Back	A	MagnaFlow	15968
4 in. Cat-Back	A	XL	15958
4 in. Turbo-Back	A	XL	15974
4 in. Cat-Back	A	Pro	17958
4 in. Turbo-Back	A	Pro	17974
1998-2002 L6 5.9L ; Ram 2500HD/3500; Crew Cab/Long Bed (96 in. Bed)			
3.5,4 in. Turbo-Back	A	MagnaFlow	15910
3.5,4 in. Turbo-Back	A	XL	15924
3.5,4 in. Turbo-Back	A	Pro	17924

CUMMINS, 5in. SINGLE HIGH-OUTPUT

2011-2011 L6 6.7L; Ram 2500HD/3500; Crew-Mega Cab/Short-Long Bed			
5 in. DPF-Back	A	MagnaFlow	16380
5 in. DPF-Back	A	XL	16381
5 in. DPF-Back	A	Pro	17916
2007-2010 L6 6.7L; Ram 2500HD/3500; Crew-Mega Cab/Short-Long Bed			
5 in. DPF-Back	A	MagnaFlow	16975
5 in. DPF-Back	A	XL	16972
5 in. DPF-Back	A	Pro	17972
2004.5-2007 5.9L I-6, Ram 2500/3500. Crew/Extended Crew Cab, Short/Long W.B.			
5 in. Cat-Back	A	MagnaFlow	16955
5 in. Cat-Back	A	XL	16956
5 in. Cat-Back	A	Pro	17956
2004.5-2007 5.9L I-6, Ram 2500/3500. Crew/Extended Crew Cab, Short/Long W.B.			
5 in. Turbo-Back	A	MagnaFlow	15986
5 in. Turbo-Back	A	XL	15989
2004.5-2007 5.9L I-6, Ram 2500/3500. Crew/Extended Crew Cab, Short/Long W.B.			
5 in. Turbo-Back	A	Pro	17989

CUMMINS, DUAL

2011-2011 L6 6.7L; Ram 2500HD/3500; Crew-Mega Cab/Short-Long Bed			
4 in. DPF-Back	F	MagnaFlow	16384
4 in. DPF-Back	F	Pro	17918
2011-2011 L6 6.7L, Ram 2500HD/3500 Crew/Mega Cab, Short/Long Bed			
4 in. DPF-Back	F	XL	16385
2007-2010 L6 6.7L; Ram 2500HD/3500; Crew-Mega Cab/Short-Long Bed			
3.5,4 in. DPF-Back	F	MagnaFlow	16974
3.5,4 in. DPF-Back	F	XL	16971
3.5,4 in. DPF-Back	F	Pro	17971
2004.5-2007 5.9L I-6, Ram 2500/3500. Crew/Extended Crew Cab, Short/Long W.B.			
4.5 in. Turbo-Back	E	MagnaFlow	15987
4.5 in. Turbo-Back	E	XL	15990
4.5 in. Turbo-Back	E	Pro	17990

EXIT STYLE CONFIGURATIONS:

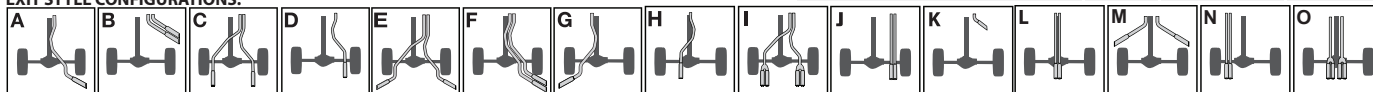

SOME DUAL SYSTEMS ON OPTIONS "C" MAY NEED MODIFICATION TO FIT AROUND TRAILER HITCHES

DODGE DIESEL

	Exit Style	Series	Part #
CUMMINS, DUAL			
2003-2004 L6 5.9L; Ram 2500HD/3500; Crew Cab/Long Bed (96 in. Bed)			
4 in. Turbo-Back	E	MagnaFlow	15963
4 in. Turbo-Back	E	XL	15973
4 in. Turbo-Back	E	Pro	17973

CUMMINS, D-FIT MUFFLER KIT

2004-2007 L6 5.9L; Ram 2500HD/3500; Crew-Mega Cab/Short-Long Bed			
4 in. D-Fit		D-Fit	16998

DODGE TRUCK

DAKOTA

2009-2011 V6 3.7L; Extended-Crew Cab/Short Bed (64.9in. Bed)			
3 in. Cat-Back	A		15522
2.5,3 in. Cat-Back	C		15523
2009-2011 V8 4.7L; Extended-Crew Cab/Short Bed (64.9in. Bed)			
2.5,3 in. Cat-Back	C		15523
3 in. Cat-Back	A		15522
2005-2008 V6 3.7L; Extended-Crew Cab/Short Bed (64.9in. Bed)			
3 in. Cat-Back	A		16621
2.5,3 in. Cat-Back	C		16622
2005-2008 V8 4.7L; Extended-Crew Cab/Short Bed (64.9in. Bed)			
3 in. Cat-Back	A		16621
2.5,3 in. Cat-Back	C		16622
2004-2004 V6 3.7L; Extended Cab/Short Bed (63in. Bed)			
2.5,3 in. Cat-Back	C		15877
3 in. Cat-Back	A		15876
2004-2004 V8 4.7L; Extended-Crew Cab/Short Bed (63in. Bed)			
2.5,3 in. Cat-Back	C		15877
3 in. Cat-Back	A		15876
2000-2003 V6 3.9L; Extended Cab (63in. Bed)			
2.5,3 in. Cat-Back	C		15736
3 in. Cat-Back	A		15657
2000-2003 V6 3.9L; Standard Cab (63in. Bed)			
2.5,3 in. Cat-Back	C		15738
3 in. Cat-Back	A		15737
2000-2003 V8 4.7L; Crew Cab (63in. Bed)			
3 in. Cat-Back	A		15739
2000-2003 V8 4.7L; Extended Cab (63in. Bed)			
3 in. Cat-Back	A		15611
2000-2003 V8 5.9L; Extended Cab (63in. Bed)			
2.5,3 in. Cat-Back	C		15736
3 in. Cat-Back	A		15657
2000-2003 V8 5.9L; Standard Cab (63in. Bed)			
2.5,3 in. Cat-Back	C		15738
3 in. Cat-Back	A		15737
1998-1999 V8 5.9L; Extended Cab (78in. Bed)			
2.5,3 in. Cat-Back	C		15735
3 in. Cat-Back	A		15656
1997-1999 V6 3.9L; Extended Cab (78in. Bed)			
2.5,3 in. Cat-Back	C		15735
3 in. Cat-Back	A		15656
1997-1999 V8 5.2L; Extended Cab (78in. Bed)			
2.5,3 in. Cat-Back	C		15735
3 in. Cat-Back	A		15656

DURANGO

2011-2012 V6 3.6L			
Cat-Back	C		15067
2011-2012 V8 5.7L; R/T			
Cat-Back	C		15068
2007-2010 V8 5.7L			
3 in. Cat-Back	D		16779
2004-2007 V8 4.7L			
3 in. Cat-Back	D		16626
2004-2006 V8 5.7L			
3 in. Cat-Back	D		15830
2000-2003 V8 4.7L			
3 in. Cat-Back	D		15659

DODGE TRUCK		Exit Style	Series	Part #
DURANGO				
2000-2003	V8 5.9L			
	3 in. Cat-Back	D		15659
1998-1999	V8 5.2L			
	3 in. Cat-Back	D		15621
1998-1999	V8 5.9L			
	3 in. Cat-Back	D		15621
NITRO				
2007-2011	V6 3.7L			
	2.5 in. Cat-Back	D		16702
2007-2011	V6 4.0L			
	2.5 in. Cat-Back	D		16702
RAM 1500 TRUCK				
2011-2011	V8 4.7L; Standard-Quad-Crew Cab/Short Bed			
	3 in. Cat-Back	A		16386
2011-2011	V8 5.7L; Standard-Quad-Crew Cab/Short Bed; W/O Factory Duals			
	3 in. Cat-Back	A		16386
2009-2011	V8 4.7L; Standard-Quad-Crew Cab/Short Bed			
	2.5,3 in. Cat-Back	B		16868
	2.5,3 in. Cat-Back	C		16870
	3 in. Cat-Back	K	Off-Road Pro	17108
2009-2011	V8 5.7L; Standard Cab/Quad Cab/Crew Cab			
	3 in. Cat-Back	K	Off-Road Pro	17108
2009-2011	V8 5.7L; Standard-Quad-Crew Cab/Short Bed; W/O Factory Duals			
	2.5,3 in. Cat-Back	B		16868
	2.5,3 in. Cat-Back	C		16870
2009-2011	V8 5.7L; Standard-Quad-Crew Cab/Short Bed, W/ Factory Duals			
	2.5,3 in. Cat-Back	C		16869
2009-2010	V8 4.7L; Standard-Quad-Crew Cab/Short Bed			
	3 in. Cat-Back	A		16867
2009-2010	V8 5.7L; Standard-Quad-Crew Cab/Short Bed; W/O Factory Duals			
	3 in. Cat-Back	A		16867
2008-2008	V8 5.7L; Mega Cab			
	3 in. Cat-Back	K	Off-Road Pro	17116
2008-2008	V8 5.7L; Mega Cab (76.3in. Bed)			
	3 in. Cat-Back	B		16852
	3 in. Cat-Back	A		16850
	2.5,3 in. Cat-Back	C		16851
2006-2007	V8 5.7L, Crew/Mega Cab, Short/Long Bed; Independent Front Suspension			
	2.5,3 in. Cat-Back	B		16701
	2.5,3 in. Cat-Back	C		16700
2006-2007	V8 5.7L, Crew/Mega Cab, Short/Long Bed; Independent Front Suspension			
	3 in. Cat-Back	A		16699
2006-2007	V8 5.7L; Crew Cab/Mega Cab			
	3 in. Cat-Back	K	Off-Road Pro	17117
2006-2006	V8 5.7L, Crew/Mega Cab, Short/Long Bed; Solid Front Axle			
	2.5,3 in. Cat-Back	C		16697
	3 in. Cat-Back	A		16696
2006-2006	V8 5.7L, Crew/Mega Cab, Short/Long Bed; Solid Front Axle			
	2.5,3 in. Cat-Back	B		16698
2006-2006	V10 8.3L			
	3 in. Cat-Back	J		16749
2004-2005	V10 8.3L			
	3 in. Cat-Back	J		15832

DODGE TRUCK		Exit Style	Series	Part #
RAM 1500 TRUCK				
2004-2005	V6 3.7L; Crew Cab (75.9in. Bed)			
	3 in. Cat-Back	A		15890
	2.5,3 in. Cat-Back	C		15891
2004-2005	V6 3.7L; Standard Cab (75.9in. Bed)			
	3 in. Cat-Back	A		15890
	2.5,3 in. Cat-Back	C		15891
2004-2005	V8 5.7L; Crew Cab/Short Bed (75.9in. Bed)			
	2.5,3 in. Cat-Back	C		15863
	3 in. Cat-Back	A		15862
2004-2005	V8 5.7L; Standard Cab/Short Bed (75.9in. Bed)			
	2.5,3 in. Cat-Back	C		15863
	3 in. Cat-Back	A		15862
2004-2004	V8 4.7L; Crew Cab (75.9in. Bed)			
	3 in. Cat-Back	A		15890
2004-2004	V8 4.7L; Crew Cab (75.9in. Bed)			
	2.5,3 in. Cat-Back	C		15891
2004-2004	V8 4.7L; Standard Cab (75.9in. Bed)			
	3 in. Cat-Back	A		15890
	2.5,3 in. Cat-Back	C		15891
2003-2003	V8 5.7L; Crew Cab (78in. Bed)			
	2.5,3 in. Cat-Back	C		15788
	3 in. Cat-Back	A		15787
2003-2003	V8 5.7L; Crew Cab (96.0 Bed)			
	2.5,3 in. Cat-Back	C		15788
	3 in. Cat-Back	A		15787
2002-2003	V8 4.7L; Crew Cab (78in. Bed)			
	3 in. Cat-Back	A		15740
	2.5,3 in. Cat-Back	C		15813
2002-2003	V8 5.9L; Crew Cab (78in. Bed)			
	3 in. Cat-Back	A		15740
	2.5,3 in. Cat-Back	C		15813
1998-2001	V6 3.9L; Extended Cab (78in. Bed)			
	2.5,3 in. Cat-Back	C		15771
	3 in. Cat-Back	A		15727
1998-2001	V8 5.2L; Extended Cab (78in. Bed)			
	2.5,3 in. Cat-Back	C		15771
	3 in. Cat-Back	A		15727
1998-2001	V8 5.9L; Extended Cab (78in. Bed)			
	2.5,3 in. Cat-Back	C		15771
	3 in. Cat-Back	A		15727
1995-1997	V6 3.9L; Extended Cab (78in. Bed)			
	3 in. Cat-Back	A		15612
1995-1997	V8 5.2L; Extended Cab (78in. Bed)			
	3 in. Cat-Back	A		15612
1995-1997	V8 5.9L; Extended Cab (78in. Bed)			
	3 in. Cat-Back	A		15612
RAM 2500 TRUCK				
2003-2003	V8 5.7L; Crew Cab (78in. Bed)			
	2.5,3 in. Cat-Back	C		15791
	3 in. Cat-Back	A		15790
2003-2003	V8 5.7L; Crew Cab (96.0 Bed)			
	2.5,3 in. Cat-Back	C		15791
	3 in. Cat-Back	A		15790
1998-2001	V10 8.0L Extended Cab Pickup, Short Bed (78.0 Bed Length)			
	3 in. Cat-Back	A		15616

EXIT STYLE CONFIGURATIONS:

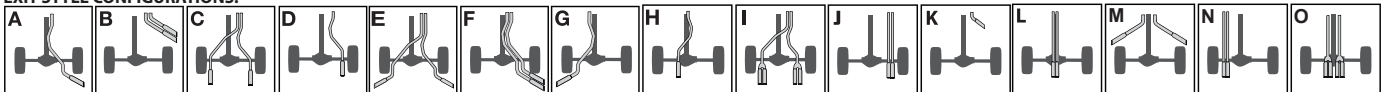

SOME DUAL SYSTEMS ON OPTIONS "C" MAY NEED MODIFICATION TO FIT AROUND TRAILER HITCHES

"We can only afford to use the best products. MagnaFlow Exhaust systems that we use have the winning combination of performance, styling, and durability. Running tours and races WIDE OPEN style is brutal on equipment, MagnaFlow Exhaust systems take whatever we throw at them...then ask for more!"—**Joshua Nettles, Wide Open Excursions, LLC**



Truck Applications

FORD DIESEL Exit Style Series Part #

6.7L DIESEL, 4in. SINGLE

Year	Model	Exit Style	Series	Part #	
2011-2011	V8 6.7L, F-250/F-350 Super Duty; Crew Cab-Short/Long Bed, Extended Cab-Long Bed	4 in. DPF-Back	A	XL	15505
		4 in. DPF-Back	A	XL	15506
		4 in. DPF-Back	A	Pro	17947

Year	Model	Exit Style	Series	Part #	
2011-2011	V8 6.7L; F-450 Super Duty-Crew Cab	4 in. DPF-Back	A	XL	15505
		4 in. DPF-Back	A	XL	15506
		4 in. DPF-Back	A	Pro	17947

6.7L DIESEL, 4in. DUAL

Year	Model	Exit Style	Series	Part #	
2011-2011	V8 6.7L, F-250/F-350 Super Duty; Crew Cab-Short/Long Bed, Extended Cab-Long Bed	4 in. DPF-Back	F	XL	15507
		4 in. DPF-Back	F	XL	15508
		4 in. DPF-Back	F	Pro	17948

Year	Model	Exit Style	Series	Part #	
2011-2011	V8 6.7L; F-450 Super Duty-Crew Cab	4 in. DPF-Back	F	XL	15507
		4 in. DPF-Back	F	XL	15508
		4 in. DPF-Back	F	Pro	17948

6.7L DIESEL, 5in. SINGLE

Year	Model	Exit Style	Series	Part #	
2011-2011	V8 6.7L, F-250/F-350 Super Duty; Crew Cab-Short/Long Bed, Extended Cab-Long Bed	5 in. DPF-Back	A	MagnaFlow	15503
		5 in. DPF-Back	A	MagnaFlow	15504
		5 in. DPF-Back	A	Pro	17946

Year	Model	Exit Style	Series	Part #	
2011-2011	V8 6.7L; F-450 Super Duty-Crew Cab	5 in. DPF-Back	A	MagnaFlow	15503
		5 in. DPF-Back	A	MagnaFlow	15504
		5 in. DPF-Back	A	Pro	17946

6.4L DIESEL, 4in. SINGLE

Year	Model	Exit Style	Series	Part #	
2008-2010	V8 6.4L; F-250/F-350 Super Duty; Crew Cab-Short/Long Bed; Extended Cab-Long Bed	4 in. DPF-Back	A	MagnaFlow	16981
		4 in. DPF-Back	A	XL	16983
		4 in. DPF-Back	A	Pro	17983

6.4L DIESEL, 4in. DUAL

Year	Model	Exit Style	Series	Part #	
2008-2010	V8 6.4L; F-250/F-350 Super Duty; Crew Cab-Short/Long Bed; Extended Cab-Long Bed	3.5,4 in. DPF-Back	F	MagnaFlow	16987
		3.5,4 in. DPF-Back	F	XL	16989
		3.5,4 in. DPF-Back	F	Pro	17988

6.4L DIESEL, 5in. SINGLE

Year	Model	Exit Style	Series	Part #	
2008-2010	V8 6.4L; F-250/F-350 Super Duty; Crew Cab-Short/Long Bed; Extended Cab-Long Bed	5 in. DPF-Back	A	MagnaFlow	16982
		V8 6.4L; F-250/F-350 Super Duty; Crew Cab-Short/Long Bed; Extended Cab-Long Bed			
2008-2010	V8 6.4L; F-250/F-350 Super Duty; Crew Cab-Short/Long Bed; Extended Cab-Long Bed	5 in. DPF-Back	A	XL	16984
		5 in. DPF-Back	A	Pro	17984

6.0L DIESEL, 4in. DUAL

Year	Model	Exit Style	Series	Part #	
2005-2007	V8 6.0L; F250/350 Super Duty, Crew Cab Short/Long Bed, Extended Cab Long Bed	4 in. Turbo-Back	E	MagnaFlow	16919
		4 in. Turbo-Back	E	XL	16923
		4 in. Turbo-Back	E	Pro	17923

Year	Model	Exit Style	Series	Part #	
2003-2007	V8 6.0L, F250/350 Superduty, Crew Cab, Short/Long Bed, DUALS	4 in. Cat-Back	E	MagnaFlow	16966
		4 in. Cat-Back	E	XL	16967
		4 in. Cat-Back	E	Pro	17967

Year	Model	Exit Style	Series	Part #	
2003-2007	V8 7.3L, F250/350 Superduty, Crew Cab, Short/Long Bed, DUALS	4 in. Cat-Back	E	MagnaFlow	16966
		4 in. Cat-Back	E	XL	16967
		4 in. Cat-Back	E	Pro	17967

Year	Model	Exit Style	Series	Part #	
2003-2004	V8 6.0L; F250/350 Super Duty, Crew Cab Short/Long Bed, Extended Cab Long Bed	4 in. Turbo-Back	E	MagnaFlow	15967
		4 in. Turbo-Back	E	XL	15977
		4 in. Turbo-Back	E	Pro	17977

FORD DIESEL Exit Style Series Part #

6.0L DIESEL, 4in. SINGLE

Year	Model	Exit Style	Series	Part #	
2005-2007	V8 6.0L; F250/350 Super Duty, Crew Cab Short/Long Bed, Extended Cab Long Bed	4 in. Turbo-Back	A	MagnaFlow	16918
		4 in. Turbo-Back	A	XL	16922
		4 in. Turbo-Back	A	Pro	17922
		4 in. Turbo-Back	K	Off-Road Pro	17133

Year	Model	Exit Style	Series	Part #	
2003-2007	V8 6.0L; F250/350 Super Duty, Crew Cab Short/Long Bed, Extended Cab Long Bed, Incl. Dually	3.5,4 in. Turbo-Back	A	MagnaFlow	15952
		3.5,4 in. Turbo-Back	A	XL	15956
		3.5,4 in. Turbo-Back	A	Pro	17957

Year	Model	Exit Style	Series	Part #	
2003-2007	V8 6.0L; F250/350 Super Duty, Crew Cab Short/Long Bed, Extended Cab Long Bed, Incl. Dually	4 in. Cat-Back	K	Off-Road Pro	17134
		4 in. Turbo-Back	K	Off-Road Pro	17133

Year	Model	Exit Style	Series	Part #	
2003-2007	V8 6.0L; F250/350 Super Duty, Crew Cab Short/Long Bed, Excl. Dually	3.5,4 in. Turbo-Back	A	MagnaFlow	15950
		3.5,4 in. Turbo-Back	A	XL	15954
		3.5,4 in. Turbo-Back	A	Pro	17954
		4 in. Turbo-Back	K	Off-Road Pro	17133

Year	Model	Exit Style	Series	Part #	
2003-2007	V8 6.0L; F250/350 Super Duty, Crew Cab, Short/Long Bed	4 in. Cat-Back	K	Off-Road Pro	17134

Year	Model	Exit Style	Series	Part #	
2003-2007	V8 7.3L, F250/350 Superduty, Crew Cab, Short/Long Bed,	4 in. Cat-Back	A	MagnaFlow	16950
		4 in. Cat-Back	A	XL	16951
		4 in. Cat-Back	A	Pro	17951

Year	Model	Exit Style	Series	Part #	
2003-2004	V8 6.0L; F250/350 Super Duty, Crew Cab Short/Long Bed, Extended Cab Long Bed	4 in. Turbo-Back	A	MagnaFlow	15971
		4 in. Turbo-Back	A	XL	15978
		4 in. Turbo-Back	A	Pro	17978

6.0L DIESEL, 5in. SINGLE

Year	Model	Exit Style	Series	Part #	
2003-2007	V8 6.0L; F250/350 Super Duty, Crew Cab Short/Long Bed, Extended Cab Long Bed, Incl. Dually	4.5 in. Turbo-Back	A	MagnaFlow	16926
		4.5 in. Turbo-Back	A	XL	16927
		4.5 in. Turbo-Back	A	Pro	17927

Year	Model	Exit Style	Series	Part #	
2003-2007	V8 6.0L; F250/350 Super Duty, Crew Cab, Short/Long Bed	5 in. Cat-Back	A	MagnaFlow	16948
		5 in. Cat-Back	A	XL	16949
		5 in. Cat-Back	A	Pro	17949

6.0L DIESEL, D-FIT MUFFLER KIT

Year	Model	Exit Style	Series	Part #	
2003-2007	V8 6.0L; F250/350 Super Duty, Crew Cab Short/Long Bed, Extended Cab Long Bed	3.5 in. D-Fit		D-Fit	16997

6.0L EXCURSION DIESEL

Year	Model	Exit Style	Series	Part #	
2003-2005	V8 6.0L	3.5,4 in. Turbo-Back	A	MagnaFlow	15960
		4 in. Turbo-Back	A	MagnaFlow	15972
		3.5,4 in. Turbo-Back	A	XL	15962
		4 in. Turbo-Back	A	XL	15982

7.3L DIESEL, 4in. SINGLE

Year	Model	Exit Style	Series	Part #	
1999-2003	V8 7.3L; F250/350 Super Duty; Crew Cab-Short/Long Bed	4 in. Cat-Back	K	Off-Road Pro	17136

Year	Model	Exit Style	Series	Part #	
1999-2003	V8 7.3L; F250/350 Super Duty; Extended-Crew Cab-Short/Long Bed	4 in. Turbo-Back	K	Off-Road Pro	17135

Year	Model	Exit Style	Series	Part #	
1999-2003	V8 7.3L, F250/350 Superduty, Crew Cab, Short/Long Bed	4 in. Cat-Back	A	MagnaFlow	16950
		4 in. Cat-Back	A	XL	16951
		4 in. Cat-Back	A	Pro	17951

Year	Model	Exit Style	Series	Part #	
1999-2003	V8 7.3L, F250/350 Superduty, Crew Cab, Short/Long Bed, Extended Cab Long Bed	4 in. Turbo-Back	A	MagnaFlow	15970
		4 in. Turbo-Back	A	XL	15979
		4 in. Turbo-Back	A	Pro	17979

Year	Model	Exit Style	Series	Part #	
1999-2003	V8 7.3L, F250/350 Superduty, Crew Cab, Short/Long Bed, Extended Cab Long Bed	3.5,4 in. Turbo-Back	A	MagnaFlow	15915
		3.5,4 in. Turbo-Back	A	XL	15928
		3.5,4 in. Turbo-Back	A	Pro	17928

EXIT STYLE CONFIGURATIONS:

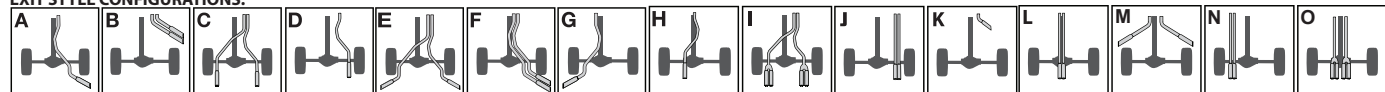

SOME DUAL SYSTEMS ON OPTIONS "C" MAY NEED MODIFICATION TO FIT AROUND TRAILER HITCHES

FORD DIESEL

7.3L DIESEL, 4in. SINGLE

Year	Model	Exit Style	Series	Part #
1999-2003	V8 7.3L, F250/350 Superduty, Crew/Extended Cab, Long Bed			
	3.5,4 in. Turbo-Back	A	XL	15945
1999-2003	V8 7.3L, F250/350 Superduty, Crew/Extended Cab, Short/Long Bed			
	4 in. Downpipe-Back	A	MagnaFlow	15900
1999-2003	V8 7.3L, F250/350 Superduty, Crew/Extended Cab, Short/Long Bed, Stock Design			
	3.5,4 in. Turbo-Back	A	MagnaFlow	15905
1994-1997	V8 7.3L, F250/350 Superduty, Crew/Extended Cab, Short/Long Bed			
	4 in. Downpipe-Back	A	XL	15939

7.3L DIESEL, 4in. DUAL

Year	Model	Exit Style	Series	Part #
1999-2003	V8 6.0L, F250/350 Superduty, Crew Cab, Short/Long Bed			
	4 in. Cat-Back	E	MagnaFlow	16966
	4 in. Cat-Back	E	XL	16967
	4 in. Cat-Back	E	Pro	17967
1999-2003	V8 7.3L, F250/350 Superduty, Crew Cab, Short/Long Bed			
	4 in. Cat-Back	E	MagnaFlow	16966
	4 in. Cat-Back	E	XL	16967
	4 in. Cat-Back	E	Pro	17967
1999-2003	V8 7.3L, F250/350 Superduty, Crew Cab, Short/Long Bed, Extended Cab Long Bed			
	4 in. Turbo-Back	E	MagnaFlow	15965
	4 in. Turbo-Back	E	XL	15980

7.3L DIESEL, 5in. SINGLE

Year	Model	Exit Style	Series	Part #
1999-2003	V8 7.3L; F250/350 Super Duty; Extended-Crew Cab-Short/Long Bed			
	5 in. Cat-Back	A	MagnaFlow	16948
	4,5 in. Turbo-Back	A	MagnaFlow	16906
	5 in. Cat-Back	A	XL	16949
	4,5 in. Turbo-Back	A	XL	16907
	4,5 in. Turbo-Back	A	Pro	17907

7.3L EXCURSION DIESEL

Year	Model	Exit Style	Series	Part #
2000-2003	DOWNPIPE-BACK			
	4 in. Downpipe-Back	A	MagnaFlow	15930
2000-2003	TURBO-BACK			
	4 in. Turbo-Back	A	MagnaFlow	15966
	4 in. Turbo-Back	A	XL	15981
2000-2003	TURBO-BACK STOCK DESIGN			
	3,5,4 in. Turbo-Back	A	MagnaFlow	15931
2000-2003	TURBO-BACK TUNER			
	3,5,4 in. Turbo-Back	A	MagnaFlow	15932
	3,5,4 in. Turbo-Back	A	XL	15942

FORD TRUCK

EDGE

Year	Model	Exit Style	Series	Part #
2011-2012	V6 3.7L			
	2.5 in. Cat-Back	C		15482
2007-2011	V6 3.5L			
	2.5 in. Cat-Back	C		16871

ESCAPE

Year	Model	Exit Style	Series	Part #
2009-2012	L4 2.5L			
	2.25 in. Cat-Back	D		16676
2005-2011	L4 2.3L			
	2.25 in. Cat-Back	D		16676
2004-2011	V6 3.0L			
	2.25 in. Cat-Back	D		16676
2004-2004	L4 2.0L			
	2.25 in. Cat-Back	D		16676

FORD TRUCK

ESCAPE

Year	Model	Exit Style	Series	Part #
2001-2003	L4 2.0L			
	2,2,2.5 in. Cat-Back	D		15663
2001-2003	V6 3.0L			
	2,2,2.5 in. Cat-Back	D		15664

EXPEDITION

Year	Model	Exit Style	Series	Part #
2010-2011	V8 5.4L			
	3 in. Cat-Back	A		16379
2010-2011	V8 5.4L EL			
	3 in. Cat-Back	A		16378
2007-2009	V8 5.4L			
	3 in. Cat-Back	A		16607
2007-2009	V8 5.4L EL			
	3 in. Cat-Back	A		16752
2003-2006	V8 5.4L			
	3 in. Cat-Back	A		15755
2003-2004	V8 4.6L			
	3 in. Cat-Back	A		15755
2001-2002	V8 4.6L			
	3 in. Cat-Back	A		15681
2001-2002	V8 5.4L			
	3 in. Cat-Back	A		15681
1997-2000	V8 4.6L			
	3 in. Cat-Back	A		15608
1997-2000	V8 5.4L			
	3 in. Cat-Back	A		15608

EXPLORER

Year	Model	Exit Style	Series	Part #
2011-2012	V6 3.5L			
	2.5 in. Cat-Back	C		15467
2006-2011	V6 4.0L			
	2.5 in. Cat-Back	G		16773
2006-2010	V8 4.6L			
	2.5 in. Cat-Back	G		16606
2002-2005	V6 4.0L			
	2.5 in. Cat-Back	G		15718
2002-2005	V8 4.6L			
	2.5 in. Cat-Back	G		15718

EXPLORER SPORT TRAC

Year	Model	Exit Style	Series	Part #
2007-2009	V8 4.6L; Excl. Adrenalin			
	2.5 in. Cat-Back	G		16679
2001-2005	V6 4.0L			
	2.5 in. Cat-Back	A		15696

F-150 HERITAGE PICKUP

Year	Model	Exit Style	Series	Part #
2004-2004	V8 4.6L; Extended Cab (78in. Bed)			
	3 in. Cat-Back	A		15609

F-150 PICKUP

Year	Model	Exit Style	Series	Part #
2011-2012	V6 3.5L Turbocharged; Extended Cab/Short Bed (78in. Bed)-Crew Cab/Short Bed (67in. Bed)			
	2,5,3 in. Cat-Back	C	Remove Spare Tire	15087
	3 in. Cat-Back	A		15458
	3 in. Cat-Back	K	Off-Road Pro	17124
2011-2012	V6 3.7L; Extended Cab/Short Bed (78in. Bed)-Crew Cab/Short Bed (67in. Bed)			
	2,5,3 in. Cat-Back	F		15461
	2,5,3 in. Cat-Back	B		15001
	2,5,3 in. Cat-Back	C		15460
	3 in. Cat-Back	A		15000

EXIT STYLE CONFIGURATIONS:

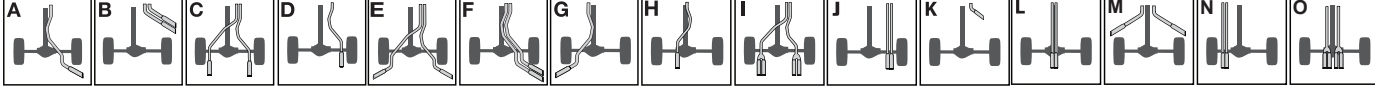

SOME DUAL SYSTEMS ON OPTIONS "C" MAY NEED MODIFICATION TO FIT AROUND TRAILER HITCHES

"MagnaFlow is a brand new product for our program, and we're thrilled to have the mufflers on our race trucks. We're looking forward to working with the engineering team on our entire exhaust system!" - **Carl Renezeder & Crew, Off-Road Championship Team**



Truck Applications

FORD TRUCK

F-150 PICKUP

Year	Model	Exit Style	Series	Part #
2011-2012	V6 3.7L; Extended-Crew Cab			
	3 in. Cat-Back	K	Off-Road Pro	17137
2011-2012	V6 3.7L; Standard Cab			
	3 in. Cat-Back	K	Off-Road Pro	17137
2011-2012	V6 3.7L; Standard Cab/Short Bed (78in. Bed)			
	3,2.5 in. Cat-Back	F		15461
	3,2.5 in. Cat-Back	C		15460
	3 in. Cat-Back	A		15000
2011-2012	V8 5.0L; Extended Cab/Short Bed (78in. Bed)-Crew Cab/Short Bed (67in. Bed)			
	3,2.5 in. Cat-Back	F		15461
	3,2.5 in. Cat-Back	B		15101
	3,2.5 in. Cat-Back	C		15460
	3 in. Cat-Back	A		15000
2011-2012	V8 5.0L; Extended-Crew Cab			
	3 in. Cat-Back	K	Off-Road Pro	17137
2011-2012	V8 5.0L; Standard Cab			
	3 in. Cat-Back	K	Off-Road Pro	17137
2011-2012	V8 5.0L; Standard Cab/Short Bed (78in. Bed)			
	3,2.5 in. Cat-Back	F		15461
	3,2.5 in. Cat-Back	C		15460
	3 in. Cat-Back	A		15000
2011-2012	V8 6.2L; Extended Cab/Short Bed (78in. Bed)-Crew Cab/Short Bed (67in. Bed)			
	3,2.5 in. Cat-Back	F		15461
	3,2.5 in. Cat-Back	C		15460
	3,2.5 in. Cat-Back	B		15105
	3 in. Cat-Back	A		15000
2011-2012	V8 6.2L; Extended-Crew Cab			
	3 in. Cat-Back	K	Off-Road Pro	17137
2010-2012	V8 5.4L; SVT Raptor; Extended Cab/Short Bed (67in. Bed)			
	3,2.5 in. Cat-Back	F		16993
2010-2012	V8 6.2L; SVT Raptor; Extended Cab/Short Bed (67in. Bed)			
	2.5 in. Cat-Back	F		15588
2009-2010	V8 4.6L; Crew Cab Short Bed, Extended Cab Short Bed			
	3,2.5 in. Cat-Back	B		16522
2009-2010	V8 5.4L; Crew Cab Short Bed, Extended Cab Short Bed			
	3,2.5 in. Cat-Back	B		16522
2009-2010	V8 4.6L; Crew Cab/Extended Cab, 66in, and 78in. Bed Lengths			
	3,2.5 in. Cat-Back	F		16523
	3,2.5 in. Cat-Back	C		16463
	3 in. Cat-Back	A		16518
2009-2010	V8 5.4L; Crew Cab/Extended Cab, 66in, and 78in. Bed Lengths			
	3,2.5 in. Cat-Back	F		16523
	3,2.5 in. Cat-Back	C		16463
	3 in. Cat-Back	A		16518
2009-2010	V8 4.6L; Standard Cab, Short Bed			
	3 in. Cat-Back	A		16517
	2.5,3 in. Cat-Back	C		16519
2009-2010	V8 5.4L; Standard Cab, Short Bed			
	3 in. Cat-Back	A		16517
	2.5,3 in. Cat-Back	C		16519
2009-2010	V8 4.6L; Standard Cab			
	3 in. Cat-Back	K	Off-Road Pro	17105
2009-2010	V8 4.6L; Standard Cab (78in. Bed)			
	2.5,3 in. Cat-Back	F		16736
2009-2010	V8 5.4L; Standard Cab			
	3 in. Cat-Back	K	Off-Road Pro	17105
2009-2010	V8 5.4L; Standard Cab (78in. Bed)			
	2.5,3 in. Cat-Back	F		16736
2006-2008	V8 5.4L; Harley Davidson Series			
	2.5,3 in. Cat-Back	F		16523
2004-2010	V8 4.6L; Extended-Crew Cab			
	3 in. Cat-Back	K	Off-Road Pro	17107

FORD TRUCK

F-150 PICKUP

Year	Model	Exit Style	Series	Part #
2004-2010	V8 5.4L; Extended-Crew Cab			
	3 in. Cat-Back	K	Off-Road Pro	17107
2004-2008	V8 4.6L Crew/Extended Cab, Short Bed, Excl. Extended Cab w/66in. Bed Length			
	2.5,3 in. Cat-Back	C		16520
	2.5 in. Cat-Back	B		16616
2004-2008	V8 5.4L Crew/Extended Cab, Short Bed, Excl. Extended Cab w/66in. Bed Length			
	2.5,3 in. Cat-Back	C		16520
	2.5 in. Cat-Back	B		16616
2004-2008	V8 4.6L, Crew/Extended Cab, Short Bed, Excl. Supercrew w/78in. Bed Length or Extended Cab w/66in. Bed Length			
	3 in. Cat-Back	A		16518
2004-2008	V8 5.4L Crew/Extended Cab, Short Bed, Excl. Supercrew w/78in. Bed Length or Extended Cab w/66in. Bed Length			
	3 in. Cat-Back	A		16518
2004-2008	V8 4.6L, Standard Cab, Short Bed			
	2.5 in. Cat-Back	B		16617
	2.5,3 in. Cat-Back	C		16615
	3 in. Cat-Back	A		16613
2004-2008	V8 5.4L Standard Cab, Short Bed			
	2.5 in. Cat-Back	B		16617
	2.5,3 in. Cat-Back	C		16615
	3 in. Cat-Back	A		16613
2004-2008	V8 4.6L; Crew Cab (66in. Bed)			
	2.5,3 in. Cat-Back	F		16523
2004-2008	V8 4.6L; Extended Cab (78in. Bed)			
	2.5,3 in. Cat-Back	F		16523
2004-2008	V8 4.6L; Standard Cab			
	3 in. Cat-Back	K	Off-Road Pro	17106
2004-2008	V8 5.4L; Crew Cab (66in. Bed)			
	2.5,3 in. Cat-Back	F		16523
2004-2008	V8 5.4L; Extended Cab (78in. Bed)			
	2.5,3 in. Cat-Back	F		16523
2004-2008	V8 5.4L; Standard Cab			
	3 in. Cat-Back	K	Off-Road Pro	17106
2002-2003	V8 5.4L; Harley Davidson Series			
	2.5 in. Cat-Back	F		15772
2001-2002	V8 4.6L; Crew Cab (66in. Bed)			
	3 in. Cat-Back	A		15609
2001-2002	V8 5.4L; Crew Cab (66in. Bed)			
	3 in. Cat-Back	A		15609
1997-2003	V8 4.6L; Extended Cab (78in. Bed)			
	2.5 in. Cat-Back	C		15749
	3 in. Cat-Back	A		15609
1997-2003	V8 5.4L; Extended Cab (78in. Bed)			
	2.5 in. Cat-Back	C		15749
	3 in. Cat-Back	A		15609

F-250 SUPER DUTY PICKUP

2011-2012	V8 6.2L; Extended Cab/Short Bed (78in. Bed)-Crew Cab/Short Bed (67in. Bed)			
	3 in. Cat-Back	A		15108
2011-2012	V8 6.2L; Extended-Crew Cab			
	3 in. Cat-Back	K	Off-Road Pro	17142
1999-2004	V10 6.8L, Crew Cab-Short/Long Bed, Extended Cab-Short Bed, Harley Davidson Edition			
	3 in. Cat-Back	A		15869

F-350 SUPER DUTY PICKUP

2011-2012	V8 6.2L; Extended Cab/Short Bed (78in. Bed)-Crew Cab/Short Bed (67in. Bed)			
	3 in. Cat-Back	A		15108
2011-2012	V8 6.2L; Extended-Crew Cab			
	3 in. Cat-Back	K	Off-Road Pro	17142
1999-2004	V10 6.8L, Crew Cab-Short/Long Bed, Extended Cab-Short Bed, Harley Davidson Edition			
	3 in. Cat-Back	A		15869

EXIT STYLE CONFIGURATIONS:

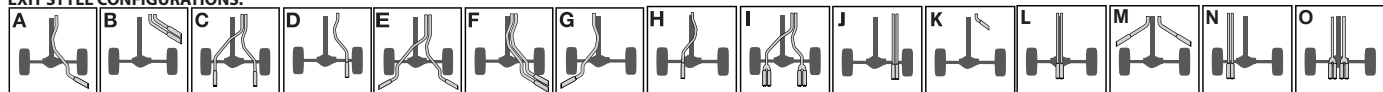

SOME DUAL SYSTEMS ON OPTIONS "C" MAY NEED MODIFICATION TO FIT AROUND TRAILER HITCHES

FORD TRUCK Exit Style Series Part #

FLEX			
2010-2012	V6 3.5L; Turbocharged 6; AWD		
	2.5 in. Cat-Back	C	16395
2009-2011	V6 3.5L		
	2.5 in. Cat-Back	N	16872
RANGER			
1998-2012	V6 4.0L; Extended Cab; Excl. Edge and Sport		
	2.5 in. Cat-Back	C	15773
	2.5 in. Cat-Back	A	15679
1998-2012	V6 4.0L; Extended-Crew Cab		
	2.5 in. Cat-Back	K	Off-Road Pro 17114
1998-2009	V6 3.0L; Extended Cab; Excl. Edge and Sport		
	2.5 in. Cat-Back	C	15773
	2.5 in. Cat-Back	A	15679
1998-2009	V6 3.0L; Extended-Crew Cab		
	2.5 in. Cat-Back	K	Off-Road Pro 17114

GMC DIESEL

DURAMAX, 4in. SINGLE

2011-2012	V8 6.6L; Silverado 2500HD/3500; Extended-Crew Cab/Short-Long Bed		
	4 in. DPF-Back	A	Pro 17908
2007-2010	V8 6.6L; Sierra 2500HD/3500; Extended-Crew Cab/Short-Long Bed		
	4 in. DPF-Back	A	MagnaFlow 16910
	4 in. DPF-Back	A	XL 16911
	4 in. DPF-Back	A	Pro 17911
2006-2007	V8 6.6L; Sierra 2500HD/3500; Extended Cab/ Long Bed (96in. Bed)		
	4 in. Cat-Back	A	MagnaFlow 16944
	4 in. Cat-Back	A	XL 16945
	4 in. Cat-Back	A	Pro 17945
2006-2007	V8 6.6L; Sierra 2500HD/3500; Crew Cab/ Short Bed (78in. Bed)		
	4 in. Cat-Back	A	MagnaFlow 16942
2006-2007	V8 6.6L; Sierra 2500HD/3500; Crew Cab/ Short Bed (78in. Bed)		
	4 in. Cat-Back	A	Pro 17943
2006-2007	V8 6.6L; Sierra 2500HD/3500; Crew Cab/ Short Bed (78in. Bed)		
	4 in. Cat-Back	A	XL 16943
2006-2007	V8 6.6L; Sierra 2500HD/3500; Extended Cab/Short Bed (78in. Bed)		
	4 in. Cat-Back	A	Pro 17964
	4 in. Turbo-Back	A	Pro 17960
2006-2007	V8 6.6L; Sierra 3500; Crew Cab/Long Bed (96in. Bed) Dually		
	4 in. Cat-Back	A	MagnaFlow 16940
	4 in. Cat-Back	A	XL 16941
	4 in. Cat-Back	A	Pro 17941
2003-2005	V8 6.6L; Sierra 2500HD/3500; Extended Cab/Short Bed (78in. Bed)		
	4 in. Cat-Back	A	Pro 17937
	4 in. Turbo-Back	A	Pro 17934
2001-2007	V8 6.6L; Sierra 2500HD/3500; Crew Cab/ Short Bed (78in. Bed)		
	4 in. Turbo-Back	A	MagnaFlow 16900
	4 in. Turbo-Back	A	XL 16902
	4 in. Turbo-Back	A	Pro 17902
	4 in. Cat-Back	K	Off-Road Pro 17128
	4 in. Turbo-Back	K	Off-Road Pro 17127
2001-2007	V8 6.6L; Sierra 2500HD/3500; Crew Cab/Long Bed (96in. Bed)		
	4 in. Cat-Back	K	Off-Road Pro 17130
	4 in. Turbo-Back	K	Off-Road Pro 17129
2001-2005	V8 6.6L; Sierra 2500HD/3500; Extended Cab/ Long Bed (96in. Bed)		
	4 in. Cat-Back	A	MagnaFlow 16934
	4 in. Cat-Back	A	XL 16935

GMC DIESEL Exit Style Series Part #

DURAMAX, 4in. SINGLE			
2001-2005	V8 6.6L; Sierra 2500HD/3500; Extended Cab/ Long Bed (96in. Bed)		
	4 in. Cat-Back	A	Pro 17935
2001-2005	V8 6.6L; Sierra 2500HD/3500; Crew Cab/ Short Bed (78in. Bed)		
	4 in. Cat-Back	A	MagnaFlow 16932
	4 in. Cat-Back	A	XL 16933
	4 in. Cat-Back	A	Pro 17933
2001-2005	V8 6.6L; Sierra 3500; Crew Cab/Long Bed (96in. Bed) Dually		
	4 in. Cat-Back	A	MagnaFlow 16930
	4 in. Cat-Back	A	XL 16931
	4 in. Cat-Back	A	Pro 17931
	4 in. Cat-Back	K	Off-Road Pro 17130
2001-2002	V8 6.6L; Sierra 2500HD/3500; Extended Cab/Short Bed (78in. Bed)		
	4 in. Turbo-Back	A	Pro 17939
	4 in. Cat-Back	A	Pro 17942

DURAMAX, 4in. DUAL

2007-2010	V8 6.6L; Sierra 2500HD/3500; Extended-Crew Cab/Short-Long Bed		
	3.5,4 in. DPF-Back	F	MagnaFlow 16914
	3.5,4 in. DPF-Back	F	XL 16915
	3.5,4 in. DPF-Back	F	Pro 17915
2006-2007	V8 6.6L; Sierra 2500HD/3500; Crew Cab/ Short Bed (78in. Bed)		
	4 in. Cat-Back	E	MagnaFlow 16964
2006-2007	V8 6.6L; Sierra 2500HD/3500; Crew Cab/ Short Bed (78in. Bed)		
	4 in. Cat-Back	E	XL 16965
	4 in. Cat-Back	E	Pro 17965
2001-2007	V8 6.6L; Sierra 2500HD/3500; Crew Cab/ Short Bed (78in. Bed)		
	4 in. Turbo-Back	E	MagnaFlow 16901
	4 in. Turbo-Back	E	XL 16903
	4 in. Turbo-Back	E	Pro 17903

DURAMAX, 5in. SINGLE

2011-2012	V8 6.6L; Silverado 2500HD/3500; Extended-Crew Cab/Short-Long Bed		
	5 in. DPF-Back	A	Pro 17910
2007-2010	V8 6.6L; Sierra 2500HD/3500; Extended-Crew Cab/Short-Long Bed		
	5 in. DPF-Back	A	MagnaFlow 16912
	5 in. DPF-Back	A	XL 16913
	5 in. DPF-Back	A	Pro 17913
2006-2007	V8 6.6L; Sierra 2500HD/3500; Crew Cab/ Short Bed (78in. Bed)		
	5 in. Cat-Back	A	MagnaFlow 16960
	5 in. Cat-Back	A	XL 16961
	5 in. Cat-Back	A	Pro 17961
2006-2007	V8 6.6L; Sierra 2500HD/3500; Crew Cab/Long Bed (96in. Bed)		
	5 in. Cat-Back	A	MagnaFlow 16962
	5 in. Cat-Back	A	XL 16963
	5 in. Cat-Back	A	Pro 17963
2006-2007	V8 6.6L; Sierra 2500HD/3500; Extended Cab/Short Bed (78in. Bed)		
	5 in. Cat-Back	A	Pro 17966
	5 in. Turbo-Back	A	Pro 17962
2003-2005	V8 6.6L; Sierra 2500HD/3500; Extended Cab/Short Bed (78in. Bed)		
	5 in. Cat-Back	A	Pro 17938
	5 in. Turbo-Back	A	Pro 17936
2001-2007	V8 6.6L; Sierra 2500HD/3500; Crew Cab/ Short Bed (78in. Bed)		
	5 in. Turbo-Back	A	MagnaFlow 16908
	5 in. Turbo-Back	A	XL 16909
	5 in. Turbo-Back	A	Pro 17909
2001-2002	V8 6.6L; Sierra 2500HD/3500; Extended Cab/Short Bed (78in. Bed)		
	5 in. Turbo-Back	A	Pro 17940
	5 in. Cat-Back	A	Pro 17944

EXIT STYLE CONFIGURATIONS:

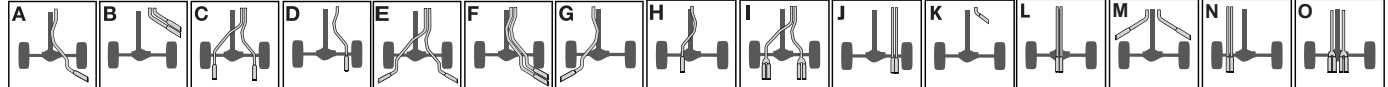

SOME DUAL SYSTEMS ON OPTIONS "C" MAY NEED MODIFICATION TO FIT AROUND TRAILER HITCHES

"MagnaFlow makes great products and has been a great support throughout the season this year. It feels really good to get on the podium to make all the hard work worth it." - **Corry Weller, LOORRS Pro SR1 class driver**



Truck Applications

GMC DIESEL

DURAMAX, D-FIT MUFFLER KIT

Year	Model	Exit Style	Series	Part #
2003-2007	V8 6.6L, Sierra 2500HD/3500; Extended Cab/ Long Bed (96in. Bed)		D-Fit	16999
	3.5 in. D-Fit			
2003-2007	V8 6.6L ; Sierra 2500HD/3500; Crew Cab/ Short Bed (78in. Bed)		D-Fit	16999
	3.5 in. D-Fit			
2003-2007	V8 6.6L ; Sierra 2500HD/3500; Crew Cab/Long Bed (96in. Bed)		D-Fit	16999
	3.5 in. D-Fit			

GMC TRUCK

C1500

Year	Model	Exit Style	Series	Part #
1996-1998	V8 5.7L; Extended Cab; (78in. Bed)			
	2.5 in. Cat-Back	C		15750
	2.5,3.5 in. Cat-Back	A		15602

C1500 SUBURBAN

Year	Model	Exit Style	Series	Part #
1996-1999	V8 5.7L			
	2.5,3.5 in. Cat-Back	A		15699
	3 in. Cat-Back	A		15700

C2500 SUBURBAN

Year	Model	Exit Style	Series	Part #
1996-1999	V8 5.7L			
	2.5,3.5 in. Cat-Back	A		15699
	3 in. Cat-Back	A		15700

CANYON

Year	Model	Exit Style	Series	Part #
2011-2011	V8 5.3L; Extended.-Crew Cab/Short Bed (61.1in Bed)			
	2.5,3 in. Cat-Back	C		15511
	3 in. Cat-Back	A		15509
2009-2010	V8 5.3L; Extended.-Crew Cab/Short Bed (61.1in Bed)			
	3 in. Cat-Back	A		15625
2007-2011	L4 2.9L, Standard Cab			
	2.25,2.5 in. Cat-Back	C		15846
	2.5 in. Cat-Back	A		15844
2007-2011	L5 3.7L Standard Cab			
	2.25,2.5 in. Cat-Back	C		15846
	2.5 in. Cat-Back	A		15844
2007-2011	L4 2.9L; Extended.-Crew Cab			
	2.25,2.5 in. Cat-Back	C		15847
	2.5 in. Cat-Back	A		15845
2007-2011	L5 3.7L Extended.-Crew Cab			
	2.25,2.5 in. Cat-Back	C		15847
	2.5 in. Cat-Back	A		15845
2004-2006	L4 2.8L, Standard Cab			
	2.25,2.5 in. Cat-Back	C		15846
	2.5 in. Cat-Back	A		15844
2004-2006	L5 3.5L Standard Cab			
	2.25,2.5 in. Cat-Back	C		15846
	2.5 in. Cat-Back	A		15844
2004-2006	L4 2.8L; Extended.-Crew Cab			
	2.25,2.5 in. Cat-Back	C		15847
	2.5 in. Cat-Back	A		15845
2004-2006	L5 3.5L Extended.-Crew Cab			
	2.25,2.5 in. Cat-Back	C		15847
	2.5 in. Cat-Back	A		15845

ENVOY

Year	Model	Exit Style	Series	Part #
2003-2010	L6 4.2L			
	2.25,3 in. Cat-Back	C		16833

K1500 SUBURBAN

Year	Model	Exit Style	Series	Part #
1996-1999	V8 5.7L			
	2.5,3.5 in. Cat-Back	A		15699
	3 in. Cat-Back	A		15700

K2500 SUBURBAN

Year	Model	Exit Style	Series	Part #
1996-1999	V8 5.7L			
	2.5,3.5 in. Cat-Back	A		15699
	3 in. Cat-Back	A		15700

GMC TRUCK

SIERRA 1500

Year	Model	Exit Style	Series	Part #
2010-2011	V6 4.3L; Standard Cab/Short Bed (78.7in. Bed)			
	3 in. Cat-Back	C		15563
	3 in. Cat-Back	A		15562
2010-2011	V8 4.8L; Crew Cab/Short Bed (69.3in Bed)			
	3 in. Cat-Back	A		15564
	2.5,3 in. Cat-Back	B		15566
	2.5,3 in. Cat-Back	C		15565
2010-2011	V8 4.8L; Extended Cab/Short Bed (78.7in Bed)			
	3 in. Cat-Back	A		15564
	2.5,3 in. Cat-Back	B		15566
	2.5,3 in. Cat-Back	C		15565
2010-2011	V8 4.8L; Standard Cab/Short Bed (78.7in. Bed)			
	3 in. Cat-Back	C		15563
	3 in. Cat-Back	A		15562
2010-2011	V8 5.3L; Crew Cab/Short Bed (69.3in Bed)			
	3 in. Cat-Back	A		15564
	2.5,3 in. Cat-Back	B		15566
	2.5,3 in. Cat-Back	C		15565
2010-2011	V8 5.3L; Extended Cab/Short Bed (78.7in Bed)			
	3 in. Cat-Back	A		15564
	2.5,3 in. Cat-Back	B		15566
	2.5,3 in. Cat-Back	C		15565
2010-2011	V8 5.3L; Standard Cab/Short Bed (78.7in. Bed)			
	3 in. Cat-Back	C		15563
	3 in. Cat-Back	A		15562
2010-2010	V8 6.0L; Crew Cab/Short Bed (69.3in Bed); Hybrid			
	3 in. Cat-Back	C		15568
	3 in. Cat-Back	A		15567
2009-2010	V6 4.3L; Extended.-Crew Cab		Off-Road Pro	17102
	3 in. Cat-Back	K		
2009-2010	V6 4.3L; Standard Cab		Off-Road Pro	17101
	3 in. Cat-Back	K		
2009-2010	V8 4.8L; Extended.-Crew Cab		Off-Road Pro	17102
	3 in. Cat-Back	K		
2009-2010	V8 4.8L; Standard Cab		Off-Road Pro	17101
	3 in. Cat-Back	K		
2009-2010	V8 5.3L; Extended.-Crew Cab		Off-Road Pro	17102
	3 in. Cat-Back	K		
2009-2010	V8 5.3L; Standard Cab		Off-Road Pro	17101
	3 in. Cat-Back	K		
2009-2009	V6 4.3L, Standard Cab, Short Bed			
	3 in. Cat-Back	A		16565
	2.5,3 in. Cat-Back	C		16566
2009-2009	V8 4.8L, Standard Cab, Short Bed			
	3 in. Cat-Back	A		16565
	2.5,3 in. Cat-Back	C		16566
2009-2009	V8 5.3L, Standard Cab, Short Bed			
	3 in. Cat-Back	A		16565
	2.5,3 in. Cat-Back	C		16566
2009-2009	V8 4.8L, Crew/Extended Cab, Short Bed, excl Hybrid			
	3,2.5 in. Cat-Back	C		16568
	3 in. Cat-Back	B		16569
	3 in. Cat-Back	A		16567
2009-2009	V8 5.3L, Crew/Extended Cab, Short Bed, excl Hybrid			
	3,2.5 in. Cat-Back	C		16568
	3 in. Cat-Back	B		16569
	3 in. Cat-Back	A		16567
2009-2009	V8 6.0L, Crew/Extended Cab, Short Bed, excl Hybrid			
	3,2.5 in. Cat-Back	C		16568
	3 in. Cat-Back	B		16569
	3 in. Cat-Back	A		16567
2007-2008	V6 4.3L, Standard Cab, Short Bed			
	2.5,3 in. Cat-Back	C		16743
	3 in. Cat-Back	A		16742

EXIT STYLE CONFIGURATIONS:

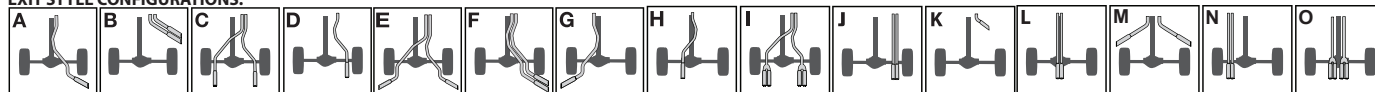

SOME DUAL SYSTEMS ON OPTIONS "C" MAY NEED MODIFICATION TO FIT AROUND TRAILER HITCHES

GMC TRUCK	Exit Style	Series	Part #
SIERRA 1500			
2007-2008	V8 4.8L, Standard Cab, Short Bed		
	2.5,3 in. Cat-Back	C	16743
	3 in. Cat-Back	A	16742
2007-2008	V8 5.3L, Standard Cab, Short Bed		
	2.5,3 in. Cat-Back	C	16743
	3 in. Cat-Back	A	16742
2007-2008	V6 4.3L; Extended-Crew Cab		
	3 in. Cat-Back	K	Off-Road Pro 17104
2007-2008	V6 4.3L; Standard Cab		
	3 in. Cat-Back	K	Off-Road Pro 17103
2007-2008	V8 4.8L, Crew/Extended Cab, Short Bed, excl Hybrid		
	3,2.5 in. Cat-Back	B	16746
	2.5,3 in. Cat-Back	C	16741
	3 in. Cat-Back	A	16740
2007-2008	V8 5.3L, Crew/Extended Cab, Short Bed, excl Hybrid		
	3,2.5 in. Cat-Back	B	16746
	2.5,3 in. Cat-Back	C	16741
	3 in. Cat-Back	A	16740
2007-2008	V8 6.0L, Crew/Extended Cab, Short Bed, excl Hybrid		
	3,2.5 in. Cat-Back	B	16746
	2.5,3 in. Cat-Back	C	16741
	3 in. Cat-Back	A	16740
2007-2008	V8 4.8L; Extended-Crew Cab		
	3 in. Cat-Back	K	Off-Road Pro 17104
2007-2008	V8 4.8L; Standard Cab		
	3 in. Cat-Back	K	Off-Road Pro 17103
2007-2008	V8 5.3L; Extended-Crew Cab		
	3 in. Cat-Back	K	Off-Road Pro 17104
2007-2008	V8 5.3L; Standard Cab		
	3 in. Cat-Back	K	Off-Road Pro 17103
2007-2007	V8 4.8L, Classic; Crew Cab/Short Bed (68.4in. Bed)		
	3 in. Cat-Back	D	15839
	2.5,3 in. Cat-Back	C	15841
2007-2007	V8 5.3L; Classic; Crew Cab/Short Bed (68.4in. Bed)		
	3 in. Cat-Back	D	15839
	2.5,3 in. Cat-Back	C	15841
2004-2006	V8 5.3L; Crew Cab (68.4in. Bed)		
	3 in. Cat-Back	D	15839
	2.5,3 in. Cat-Back	C	15841
2004-2004	V8 5.3L; Crew Cab (78in. Bed)		
	3 in. Cat-Back	D	15839
	2.5,3 in. Cat-Back	C	15841
2003-2007	V6, 4.3L, Classic Extended Cab Short Bed		
	2.5,3 in. Cat-Back	B	15842
	3 in. Cat-Back	A	15778
2003-2007	V8, 4.8L, Classic Extended Cab Short Bed		
	2.5,3 in. Cat-Back	B	15842
	3 in. Cat-Back	A	15778
2003-2007	V8, 5.3L Classic Extended Cab Short Bed		
	2.5,3 in. Cat-Back	B	15842
	3 in. Cat-Back	A	15778
2003-2007	V6 4.3L Classic Standard Cab Short Bed		
	2.5,3 in. Cat-Back	C	15794
2003-2007	V8 4.8L Classic Standard Cab Short Bed		
	2.5,3 in. Cat-Back	C	15794

GMC TRUCK	Exit Style	Series	Part #
SIERRA 1500			
2003-2007	V8 5.3L Classic Standard Cab Short Bed		
	2.5,3 in. Cat-Back	C	15794
2003-2007	V6, 4.3L, Classic Extended Cab Short Bed		
	2.5,3 in. Cat-Back	C	15792
2003-2007	V8, 4.8L, Classic Extended Cab Short Bed		
	2.5,3 in. Cat-Back	C	15792
2003-2007	V8, 5.3L Classic Extended Cab Short Bed		
	2.5,3 in. Cat-Back	C	15792
2003-2007	V6 4.3L Classic Standard Cab Short Bed		
	3 in. Cat-Back	A	15818
2003-2007	V8 4.8L Classic Standard Cab Short Bed		
	3 in. Cat-Back	A	15818
2003-2007	V8 5.3L Classic Standard Cab Short Bed		
	3 in. Cat-Back	A	15818
2003-2006	V8 6.0L; Extended Cab (78in. Bed)		
	2.5,3 in. Cat-Back	D	15838
	2.5 in. Cat-Back	C	15840
1999-2002	V6 4.3L Extended Cab, Short Bed		
	3 in. Cat-Back	A	15618
	2.5,3 in. Cat-Back	C	15754
1999-2002	V8 4.8L Extended Cab, Short Bed		
	3 in. Cat-Back	A	15618
	2.5,3 in. Cat-Back	C	15754
1999-2002	V8 5.3L Extended Cab, Short Bed		
	3 in. Cat-Back	A	15618
	2.5,3 in. Cat-Back	C	15754
1999-2002	V6 4.3L Standard Cab, Short Bed		
	2.5,3 in. Cat-Back	C	15753
	3 in. Cat-Back	A	15617
1999-2002	V8 4.8L Standard Cab, Short Bed		
	2.5,3 in. Cat-Back	C	15753
	3 in. Cat-Back	A	15617
1999-2002	V8 5.3L Standard Cab, Short Bed		
	2.5,3 in. Cat-Back	C	15753
	3 in. Cat-Back	A	15617
SIERRA 1500 HD			
2007-2007	V8 6.0L; Classic HD; Crew Cab/Short Bed		
	3,4 in. Cat-Back	A	15782
	2.5,3 in. Cat-Back	C	15828
2003-2006	V8 6.0L; Crew Cab/Short Bed		
	3,4 in. Cat-Back	A	15782
	2.5,3 in. Cat-Back	C	15828
2001-2002	V8 6.0L		
	3,4 in. Cat-Back	A	15728
SIERRA 2500			
2001-2002	V8 6.0L; Extended Cab (96in. Bed)		
	3,4 in. Cat-Back	A	15780
SIERRA 2500 HD			
2007-2008	V8 6.0L; Crew Cab/Long Bed (97.6in Bed)		
	3.5,4 in. Cat-Back	A	16789
	3,3.5 in. Cat-Back	C	16790
2007-2007	V8 6.0L; Classic HD; Crew Cab/Short Bed (78in. Bed)		
	3,4 in. Cat-Back	A	15789
	2.5,3 in. Cat-Back	C	15829

EXIT STYLE CONFIGURATIONS:

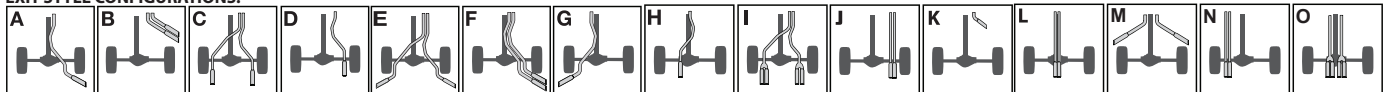

SOME DUAL SYSTEMS ON OPTIONS "C" MAY NEED MODIFICATION TO FIT AROUND TRAILER HITCHES

"After racing my Truck, I noticed a huge difference not only from the additional horsepower gains but also the quieter exhaust tone that helps me maintain communications with team throughout a race. MagnaFlow gives me the leading edge in each and every race!" – **Greg Adler, Team 4Wheel Parts Driver**



Truck Applications

GMC TRUCK

	Exit Style	Series	Part #
SIERRA 2500 HD			
2003-2006	V8 6.0L; Crew Cab/Short Bed (78in. Bed)		
	3,4 in. Cat-Back	A	15789
	2,5,3 in. Cat-Back	C	15829
2001-2002	V8 6.0L; Crew Cab (78in. Bed)		
	3,4 in. Cat-Back	A	15732
	2,5,3 in. Cat-Back	C	15829
2001-2002	V8 8.1L; Extended Cab (96in. Bed)		
	3,4 in. Cat-Back	A	15779

SIERRA DENALI

2009-2011	V8 6.2L		
	2,5,3,5 in. Cat-Back	C	15574
	3,5 in. Cat-Back	D	15573

SONOMA

2001-2004	V6 4.3L; Crew Cab (55.2in. Bed)		
	2,5 in. Cat-Back	A	15825
2000-2003	V6 4.3L; Extended Cab; (73.1in. Bed); Excl. ZR2		
	2,5 in. Cat-Back	C	15796
	2,5 in. Cat-Back	A	15661
1998-2003	L4 2.2L; Extended Cab; (73.1in. Bed)		
	2,25 in. Cat-Back	A	15662
1998-2003	L4 2.2L; Standard Cab; (73.1in. Bed)		
	2,25 in. Cat-Back	A	15706
1998-1999	V6 4.3L; Extended Cab; (73.1in. Bed)		
	2,5 in. Cat-Back	C	15776
	2,5 in. Cat-Back	A	15777

TERRAIN

2010-2012	L4 2.4L		
	2,5 in. Cat-Back	C	15110
2010-2012	V6 3.0L		
	2,5 in. Cat-Back	C	15110

YUKON

2010-2011	V8 5.3L		
	3 in. Cat-Back	A	15571
2009-2009	V8 4.8L		
	3 in. Cat-Back	A	16564
2009-2009	V8 5.3L		
	3 in. Cat-Back	A	16564
2007-2008	V8 4.8L		
	3 in. Cat-Back	A	16672
2007-2008	V8 5.3L		
	3 in. Cat-Back	A	16672
2000-2006	V8 4.8L		
	3 in. Cat-Back	A	15666
2000-2006	V8 5.3L		
	3 in. Cat-Back	A	15666
1996-1998	V8 5.7L; 4-Door		
	2,5,3 in. Cat-Back; Dual Inlet	A	15701
	3 in. Cat-Back; Single Inlet	A	15702

YUKON 1500 DENALI XL

2007-2008	V8 6.2L		
	3,5 in. Cat-Back	D	16720
2003-2006	V8 6.0L		
	2,5,3 in. Cat-Back	A	15837

YUKON DENALI

2007-2008	V8 6.2L		
	3,5 in. Cat-Back	A	16671
2002-2006	V8 6.0L		
	2,5,3,5 in. Cat-Back	A	15734
1999-1999	V8 5.7L; 4-Door		
	2,5,3 in. Cat-Back	A	15701
	3 in. Cat-Back	A	15702

GMC TRUCK

	Exit Style	Series	Part #
YUKON XL 1500			
2010-2011	V8 6.2L		
	3,5 in. Cat-Back	D	15111
2009-2011	V8 5.3L		
	3 in. Cat-Back	A	15569
2007-2008	V8 5.3L		
	3 in. Cat-Back	A	16722
2000-2006	V8 5.3L		
	3 in. Cat-Back	A	15665

YUKON XL 2500

2009-2011	V8 6.0L		
	3 in. Cat-Back	A	15570
2007-2008	V8 6.0L		
	2,5,3 in. Cat-Back	A	16725
2001-2006	V8 8.1L		
	3,4 in. Cat-Back	A	15716
2000-2006	V8 6.0L		
	3,4 in. Cat-Back	A	15798

HONDA TRUCK

RIDGELINE

2006-2012	V6 3.5L		
	2,5 in. Cat-Back	D	16669

HUMMER TRUCK

H2

2009-2010	V8 6.2L		
	2,5,3,5 in. Cat-Back	C	16474
	3,5 in. Cat-Back	D	16473

2007-2008

	V8 6.2L		
	2,5,3,5 in. Cat-Back	C	16772
	3,5 in. Cat-Back	D	16771

2007-2008

	V8 6.0L		
	2,5,3,5 in. Cat-Back	C	16772
	3,5 in. Cat-Back	D	16771

2005-2006

	V8 6.0L; Excl. Air Suspension W/ Dual Compressors		
	2,5,3 in. Cat-Back	C	16673
	2,5,3 in. Cat-Back	J	15770

2003-2004

	V8 6.0L		
	2,5,3 in. Cat-Back	C	16673
	2,5,3 in. Cat-Back	J	15770

H3

2009-2010	L5 3.7L; H3T		
	2,5 in. Cat-Back	D	16591

2009-2010

	V8 5.3L; H3T		
	3 in. Cat-Back	A	16592

2008-2010

	V8 5.3L; Alpha		
	2,5,3 in. Cat-Back	C	16832

2007-2010

	L5 3.7L		
	2,5 in. Cat-Back	C	16630

2006-2006

	L5 3.5L		
	2,5 in. Cat-Back	C	16630

INFINITI TRUCK

QX56

2010-2011	V8 5.6L		
	2,5,3 in. Cat-Back	A	15575
2007-2009	V8 5.6L		
	2,25,3 in. Cat-Back	A	16783
2004-2006	V8 5.6L		
	3 in. Cat-Back	A	15850

ISUZU TRUCK

ASCENDER

2008-2009	L6 4.2L		
	2,25,3 in. Cat-Back	C	16833
2003-2007	I6 4.2L; W/ 113in. WB		
	2,25,3 in. Cat-Back	C	16833

EXIT STYLE CONFIGURATIONS:

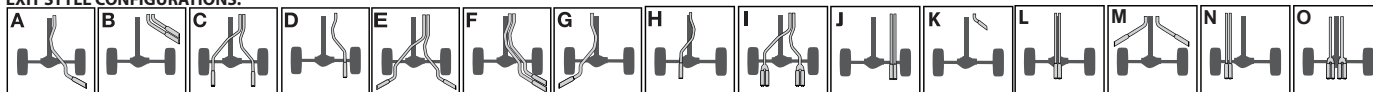

SOME DUAL SYSTEMS ON OPTIONS "C" MAY NEED MODIFICATION TO FIT AROUND TRAILER HITCHES

ISUZU TRUCK		Exit Style	Series	Part #
I-280				
2006-2006	L4 2.8L			
	2.25,2.5 in. Cat-Back	C		15847
	2.5 in. Cat-Back	A		15845
I-290				
2007-2009	L4 2.9L			
	2.25,2.5 in. Cat-Back	C		15847
	2.5 in. Cat-Back	A		15845
I-350				
2006-2006	L5 3.5L			
	2.25,2.5 in. Cat-Back	C		15847
	2.5 in. Cat-Back	A		15845
I-370				
2007-2009	L5 3.7L			
	2.25,2.5 in. Cat-Back	C		15847
	2.5 in. Cat-Back	A		15845
JEEP TRUCK				
CHEROKEE				
2000-2001	L6 4.0L; From 1/21/00			
	0 in. Cat-Back	A		16464
1996-2000	L4 2.5L			
	2.5 in. Cat-Back	D		15856
1996-2000	L6 4.0L; To 1/20/00			
	2.5 in. Cat-Back	D		15856
COMMANDER				
2006-2010	V8 5.7L			
	2.5 in. Cat-Back	D		16665
COMPASS				
2011-2012	L4 2.0L			
	Cat-Back	D		15062
2011-2012	L4 2.4L			
	Cat-Back	D		15063
2007-2010	L4 2.4L; AWD			
	2.25 in. Cat-Back	D		16777
2007-2010	L4 2.4L; FWD			
	2.25 in. Cat-Back	D		16778
GRAND CHEROKEE				
2012-2012	V8 6.4L; SRT-8			
	Cat-Back	C		15064
2011-2012	V6 3.6L			
	2.5 in. Cat-Back	D		16991
2011-2012	V8 5.7L			
	2.5 in. Cat-Back	C		16929
2007-2009	V6 3.7L			
	2.5 in. Cat-Back	D		16834
2007-2008	V6 3.0L			
	3 in. Cat-Back	D		16812
2006-2010	V8 6.1L			
	3 in. Cat-Back	L		16709
2005-2010	V8 4.7L			
	2.5 in. Cat-Back	D		16632
2005-2010	V8 5.7L			
	2.5 in. Cat-Back	D		16631
2005-2006	V6 3.7L			
	2.5 in. Cat-Back	D		16632

JEEP TRUCK		Exit Style	Series	Part #
GRAND CHEROKEE				
1999-2004	L6 4.0L			
	2.5 in. Cat-Back	D		15859
1999-2004	V8 4.7L			
	2.5 in. Cat-Back	D		15859
1998-1998	V8 5.9L			
	2.5 in. Cat-Back	D		15858
1993-1997	L6 4.0L			
	2.5 in. Cat-Back	D		15857
1993-1997	V8 5.2L			
	2.5 in. Cat-Back	D		15857
LIBERTY				
2008-2012	V6 3.7L			
	2.25 in. Cat-Back	A		16874
2007-2007	V6 3.7L			
	2.5 in. Cat-Back	D		16774
2004-2006	V6 3.7L; Incl. Renegade			
	2.5 in. Cat-Back	D		15870
2004-2005	L4 2.4L			
	2.5 in. Cat-Back	D		15870
2002-2003	V6 3.7L			
	2.5 in. Cat-Back	D		15721
PATRIOT				
2007-2010	L4 2.4L			
	2.25 in. Cat-Back	A		16763
WRANGLER				
2012-2012	V6 3.6L			
	2.5 in. Cat-Back	D		15115
2007-2012	V6 3.8L			
	2.5 in. Cat-Back	D		16666
	2.5 in. Cat-Back	D	Competition	16393
	2.5 in. Cat-Back	K	Off-Road Pro	17119
2007-2011	V6 3.8L; Unlimited 4 Door			
	2.5 in. Cat-Back	D		16751
	2.5 in. Cat-Back	D	Competition	16391
2007-2012	V6 3.8L; Unlimited 4 Door			
	2.5 in. Cat-Back	K	Off-Road Pro	17120
2004-2006	L6 4.0L; Unlimited			
	2.5 in. Cat-Back	D		16695
	2.5 in. Cat-Back	D	Competition	16389
	2.5 in. Cat-Back	K	Off-Road Pro	17121
2003-2006	L4 2.4L			
	2.5 in. Cat-Back	D		15855
	2.5 in. Cat-Back	K	Off-Road Pro	17122
2000-2006	L6 4.0L			
	2.5 in. Cat-Back	D		15855
	2.5 in. Cat-Back	D	Competition	16390
	2.5 in. Cat-Back	K	Off-Road Pro	17122
2000-2002	L4 2.5L			
	2.5 in. Cat-Back	D		15855
	2.5 in. Cat-Back	D	Competition	16390
	2.5 in. Cat-Back	K	Off-Road Pro	17122
1997-1999	L4 2.5L			
	2.5 in. Cat-Back	D		15854
	3 in. Cat-Back	K	Off-Road Pro	17125
1997-1999	L6 4.0L			
	2.5 in. Cat-Back	D		15854
	3 in. Cat-Back	K	Off-Road Pro	17125

EXIT STYLE CONFIGURATIONS:

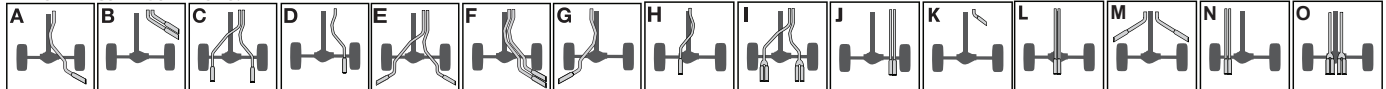

SOME DUAL SYSTEMS ON OPTIONS "C" MAY NEED MODIFICATION TO FIT AROUND TRAILER HITCHES

"No matter if we are looking for that extra horsepower, the rumble we all live for, or the clean look that sets us apart, MagnaFlow is the only choice for TEAM CANIDAE. We are so impressed with the quality, workmanship and performance that we even run an entire MagnaFlow exhaust system behind our 800 HP Trophy Truck. If it lasts for us, it will last for you." -**Scott Whipple, Team CANIDAE**



Truck Applications

JEEP TRUCK

	Exit Style	Series	Part #
WRANGLER			
1991-1995	L4 2.5L		
	2.5 in. Cat-Back	D	15853
	3 in. Cat-Back	K	17126
1991-1995	L6 4.0L		
	2.5 in. Cat-Back	D	15853
	3 in. Cat-Back	K	17126

LAND ROVER TRUCK

DEFENDER 90

1997-1997	8 4.0L		
	2.5 in. Cat-Back	G	16711
1994-1995	8 3.9L		
	2.5 in. Cat-Back	G	16711

DISCOVERY

2003-2004	V8 4.6L		
	2.5 in. Cat-Back	H	16888
1999-2002	V8 4.0L; Discovery II		
	2.5 in. Cat-Back	H	16888
1996-1999	V8 4.0L; Discovery I		
	2.5 in. Cat-Back	H	16896
1994-1995	V8 3.9L		
	2.5 in. Cat-Back	H	16896

LR2

2008-2012	L6 3.2L		
	2.5 in. Cat-Back	C	15576

LR3

2005-2008	V6 4.0L; SE		
	2.5 in. Cat-Back	H	16895
2005-2008	V8 4.4L; HSE		
	2.5 in. Cat-Back	H	16895

LR4

2010-2012	V8 5.0L		
	2.5 in. Cat-Back	C	15577

RANGE ROVER EVOQUE

2012-2012	L4 2.0L		
	Cat-Back	C	15065

RANGE ROVER EVOQUE COUPE

2012-2012	L4 2.0L		
	Cat-Back	C	15066

RANGE ROVER

2010-2012	8 5.0L		
	2.5 in. Cat-Back	C	15578
2010-2012	8 5.0L; Supercharged		
	2.5 in. Cat-Back	C	15579
2006-2009	8 4.4L		
	2.25 in. Cat-Back	C	16715
2003-2005	8 4.4L		
	2.25 in. Cat-Back	C	16714
1996-2002	8 4.6L		
	2.5 in. Cat-Back	D	16899
	2.5 in. Cat-Back	C	16898
1995-2000	8 4.0L		
	2.5 in. Cat-Back	D	16899
	2.5 in. Cat-Back	C	16898
1993-1995	8 4.2L; Country LWB		
	2.5 in. Cat-Back	G	16713
1990-1995	8 3.9L		
	2.5 in. Cat-Back	G	16713
RANGE ROVER SPORT			
2010-2012	V8 5.0L; Supercharged		
	2.5 in. Cat-Back	C	15579
2006-2009	V8 4.2L; Supercharged		
	2.5 in. Cat-Back	C	16897
2006-2009	V8 4.4L; HSE		
	2.5 in. Cat-Back	C	16897

EXIT STYLE CONFIGURATIONS:

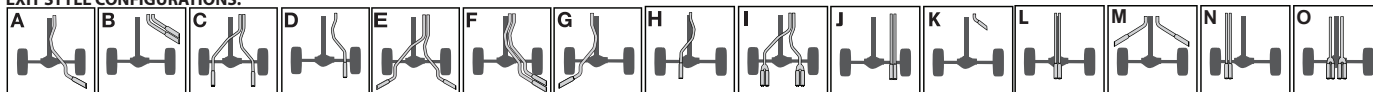

SOME DUAL SYSTEMS ON OPTIONS "C" MAY NEED MODIFICATION TO FIT AROUND TRAILER HITCHES

LINCOLN TRUCK

	Exit Style	Series	Part #
AVIATOR			
2004-2005	V8 4.6L		
	2.5 in. Cat-Back	G	16937

MARK LT

2006-2008	V8 4.6L Crew Cab/Extended Cab, 66in, and 78in. Bed Lengths		
	2.5,3 in. Cat-Back	F	16523
	2.5,3 in. Cat-Back	C	16520
	3 in. Cat-Back	A	16518

2006-2008 V8 5.4L, Crew Cab/Extended Cab, 66in, and 78in. Bed Lengths

	2.5,3 in. Cat-Back	F	16523
	2.5,3 in. Cat-Back	C	16520
	3 in. Cat-Back	A	16518

2006-2008 V8 4.6L Crew/Extended Cab, Short Bed, Excl. Extended Cab w/66in. Bed Length

	2.5 in. Cat-Back	B	16616
--	------------------	---	-------

2006-2008 V8 5.4L Crew/Extended Cab, Short Bed, Excl. Extended Cab w/66in. Bed Length

	2.5 in. Cat-Back	B	16616
--	------------------	---	-------

2006-2008 V8 5.4L; Crew Cab (66in. Bed)

	3 in. Cat-Back	K	17107
--	----------------	---	-------

MKX

2011-2011 V6 3.7L

	2.5 in. Cat-Back	C	15482
--	------------------	---	-------

2007-2011 V6 3.5L

	2.5 in. Cat-Back	C	16871
--	------------------	---	-------

NAVIGATOR

2008-2010 V8 5.4L

	3 in. Cat-Back	D	16765
--	----------------	---	-------

2007-2010 V8 5.4L; L Models

	3 in. Cat-Back	D	16776
--	----------------	---	-------

2003-2006 V8 5.4L

	3 in. Cat-Back	A	15872
--	----------------	---	-------

2001-2002 V8 5.4L

	3 in. Cat-Back	A	15681
--	----------------	---	-------

1998-2000 V8 5.4L

	3 in. Cat-Back	A	15608
--	----------------	---	-------

MAZDA TRUCK

B3000

1998-2007 V6 3.0L; Extended Cab

	2.5 in. Cat-Back	C	15773
	2.5 in. Cat-Back	A	15679
	2.5 in. Cat-Back	K	17114

B4000

1998-2009 V6 4.0L

	2.5 in. Cat-Back	C	15773
	2.5 in. Cat-Back	A	15679
	2.5 in. Cat-Back	K	17114

TRIBUTE

2004-2008 V6 3.0L

	2.25 in. Cat-Back	D	16676
--	-------------------	---	-------

2001-2003 L4 2.0L

	2,2.25 in. Cat-Back	D	15663
--	---------------------	---	-------

2001-2003 V6 3.0L

	2,2.25 in. Cat-Back	D	15664
--	---------------------	---	-------

MERCURY TRUCK

MOUNTAINEER

2006-2010 V8 4.6L

	2.5 in. Cat-Back	G	16606
--	------------------	---	-------

2002-2005 V6 4.0L

	2.5 in. Cat-Back	G	15718
--	------------------	---	-------

2002-2005 V8 4.6L

	2.5 in. Cat-Back	G	15718
--	------------------	---	-------

MITSUBISHI TRUCK Exit Style Series Part #

RAIDER			
2009-2009	V6 3.7L; Extended-Crew Cab/Short Bed (64.9in. Bed)		
	3 in. Cat-Back	A	15522
	2.5,3 in. Cat-Back	C	15523
2006-2008	V6 3.7L; Extended-Crew Cab		
	3 in. Cat-Back	A	16621
	2.5,3 in. Cat-Back	C	16622
2006-2008	V8 4.7L; Extended-Crew Cab		
	3 in. Cat-Back	A	16621
	2.5,3 in. Cat-Back	C	16622

NISSAN TRUCK

ARMADA			
2010-2011	V8 5.6L		
	2.5,3 in. Cat-Back	A	15575
2007-2009	V8 5.6L		
	2.25,3 in. Cat-Back	A	16783
2005-2006	V8 5.6L		
	3 in. Cat-Back	A	15850
FRONTIER			
2010-2011	V6 4.0L; Extended-Crew Cab/Short Bed (58.6in. Bed)		
	3 in. Cat-Back	A	15580
2005-2009	V6 4.0L; Extended-Crew Cab/Short Bed (58.6in. Bed)		
	3 in. Cat-Back	A	16627
2002-2004	L4 2.4L; Extended Cab (74.6in. Bed)		
	2.5 in. Cat-Back	G	15880
2002-2004	V6 3.3L; Crew Cab (74.6in. Bed)		
	2.5 in. Cat-Back	G	15866
2002-2004	V6 3.3L; Extended Cab (74.6in. Bed)		
	2.5 in. Cat-Back	G	15865

JUKE			
2011-2011	L4 1.6L Turbocharged		
	2.25 in. Cat-Back	H	15489

TITAN			
2010-2011	V8 5.6L; Extended-Crew Cab/Short Bed (67.1in. Bed)		
	2.25,2.5 in. Cat-Back	C	15582
2007-2010	V8 5.6L; Extended-Crew Cab		
	3 in. Cat-Back	K	Off-Road Pro 17109
2007-2010	V8 5.6L; Extended-Crew Cab/Short Bed (67.1in. Bed)		
	2.25,3 in. Cat-Back	A	16780
2007-2009	V8 5.6L; Extended-Crew Cab/Short Bed (67.1in. Bed)		
	2.25,2.5 in. Cat-Back	C	16781
2004-2006	V8 5.6L; Extended-Crew Cab		
	3 in. Cat-Back	K	Off-Road Pro 17110
2004-2006	V8 5.6L; Extended-Crew Cab/Short Bed (67.1in. Bed)		
	2.5,3 in. Cat-Back	C	15849
	3 in. Cat-Back	A	15848

XTERRA			
2010-2011	V6 4.0L		
	3 in. Cat-Back	A	15583
2005-2009	V6 4.0L		
	2.5 in. Cat-Back	A	16654
2002-2004	V6 3.3L		
	2.5 in. Cat-Back	G	15867

SATURN TRUCK Exit Style Series Part #

VUE			
2004-2007	V6 3.5L		
	2.5 in. Cat-Back	D	16785

TOYOTA TRUCK

4RUNNER			
2009-2011	V6 4.0L		
	3 in. Cat-Back	A	15584
2003-2008	V6 4.0L		
	2.5 in. Cat-Back	F	15781
2003-2006	V8 4.7L		
	2.5 in. Cat-Back	F	15781

FJ CRUISER			
2007-2011	V6 4.0L		
	2.5 in. Cat-Back	D	16649

SEQUOIA			
2001-2006	V8 4.7L		
	2.5,3 in. Cat-Back	D	15808

TACOMA			
2005-2011	L4 2.7L; Extended-Crew Cab/Short Bed (60.3in. Bed)		
	2.5,3 in. Cat-Back	A	16625
2005-2011	V6 4.0L; Crew Cab (60.3in. Bed); 2 WD Pre-Runner; 4 WD; TRD		
	2.5,3 in. Cat-Back	A	16625
2005-2011	V6 4.0L; Extended-Crew Cab/Short Bed		
	2.5 in. Cat-Back	K	Off-Road Pro 17115
2005-2009	V6 4.0L; High-Output; X-Runner		
	2.5,3 in. Cat-Back	A	16624
2001-2004	L4 2.7L; Extended-Crew Cab; W/ 12..9in. WB; 2 WD Pre-Runner; 4 WD; TRD; 2 WD Pre-Runner; 4 WD; TRD		
	2.5 in. Cat-Back	A	15811
2001-2004	V6 3.4L; Extended Cab; S-Runner; 2 WD /Short Bed (61.5in Bed)		
	2.5 in. Cat-Back	A	15810
2001-2004	V6 3.4L; Extended-Crew Cab; 4 WD; 121.9in. WB; 2 WD Pre-Runner; 4 WD; TRD		
	2.5 in. Cat-Back	A	15811
2001-2004	V6 3.4L; Extended-Crew Cab; Pre-Runner (121.9in. WB); 2 WD Pre-Runner; 4 WD; TRD		
	2.5 in. Cat-Back	A	15811
2000-2000	L4 2.7L; Extended Cab; Pre-Runner (121.9in. WB)		
	2.5 in. Cat-Back	A	15811
2000-2000	V6 3.4L; Extended Cab; 4 WD (121.9in. WB)		
	2.5 in. Cat-Back	A	15811
2000-2000	V6 3.4L; Extended Cab; Pre-Runner (121.9in. WB)		
	2.5 in. Cat-Back	A	15811

TUNDRA			
2010-2011	V8 4.6L; Crew Cab (78.7in. Bed)		
	2.5,3 in. Cat-Back	A	16470
	2.5 in. Cat-Back	F	16471
	2.5 in. Cat-Back	C	15585
2010-2011	V8 4.6L; Extended Cab (78.7in. Bed)		
	2.5,3 in. Cat-Back	A	16470
	2.5 in. Cat-Back	F	16471
	2.5 in. Cat-Back	C	15585
2009-2011	V8 5.7L; Crew Cab (66.7in. Bed); From 8/08		
	2.5,3 in. Cat-Back	A	16485
	2.5 in. Cat-Back	F	16486
	2.5 in. Cat-Back	C	16487

EXIT STYLE CONFIGURATIONS:

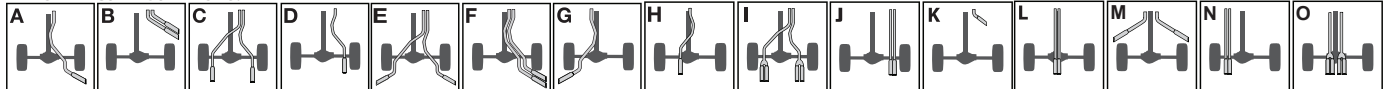

SOME DUAL SYSTEMS ON OPTIONS "C" MAY NEED MODIFICATION TO FIT AROUND TRAILER HITCHES

“The addition of MagnaFlow Performance exhaust to the Toyo Tire/ MagnaFlow prolite has greatly improved the performance of the truck, most importantly when we need to get every ounce of horsepower out of our motors! “ – **Aaron Daugherty, Pro Lite 2 Driver**



Truck Applications

TOYOTA TRUCK		Exit Style	Series	Part #
TUNDRA				
2009-2011	V8 5.7L; Extended Cab (78.7in. Bed); From 8/08			
	2.5,3 in. Cat-Back	A		16485
	2.5 in. Cat-Back	F		16486
	2.5 in. Cat-Back	C		16487
2009-2011	V8 5.7L; Extended-Crew Cab; Excl Longbed			
	2.5 in. Cat-Back	K	Off-Road Pro	17111
2009-2011	V8 5.7L; Standard Cab (78.7in. Bed); From 8/08			
	2.5,3 in. Cat-Back	A		16488
	2.5 in. Cat-Back	F		16489
	2.5 in. Cat-Back	C		16490
2007-2009	V8 4.7L; Extended Cab (78.7in. Bed)			
	2.5, 3 in. Cat-Back	A		16877
	2.5 in. Cat-Back	C		16879
	2.25,2.5 in. Cat-Back	F		16878
2007-2008	V8 5.7L; Crew Cab (66.7in. Bed); To 7/08			
	2.5 in. Cat-Back	F		16782
	2.5 in. Cat-Back	C		16865
	2.3 in. Cat-Back	A		16753
2007-2008	V8 5.7L; Extended Cab (78.7in. Bed); To 7/08			
	2.5 in. Cat-Back	F		16782
	2.5 in. Cat-Back	C		16865
	2.3 in. Cat-Back	A		16753
2007-2008	V8 5.7L; Extended-Crew Cab; Excl Longbed			
	2.5 in. Cat-Back	K	Off-Road Pro	17112
2007-2008	V8 5.7L; Standard Cab; Excl Longbed			
	2.5 in. Cat-Back	K	Off-Road Pro	17113
2007-2008	V8 5.7L; Standard Cab (78.7in. Bed); To 7/08			
	2.5,3 in. Cat-Back	A		16770
	2.5 in. Cat-Back	C		16775
	2.5 in. Cat-Back	F		16653
2004-2006	V8 4.7L; Crew Cab (74.7in. Bed)			
	2.5,3 in. Cat-Back	A		15809
	2.5 in. Cat-Back	F		15820
2004-2006	V8 4.7L; Extended Cab (74.7in. Bed)			
	2.5,3 in. Cat-Back	A		15809
	2.5 in. Cat-Back	F		15820
	2.5 in. Cat-Back	C		16864
2004-2004	V6 3.4L; Crew Cab (74.7in. Bed)			
	2.5,3 in. Cat-Back	A		15809
	2.5 in. Cat-Back	F		15820
	2.5 in. Cat-Back	C		16864
2004-2004	V6 3.4L; Extended Cab (74.7in. Bed)			
	2.5,3 in. Cat-Back	A		15809
	2.5 in. Cat-Back	F		15820
	2.5 in. Cat-Back	C		16864
2000-2003	V6 3.4L; Extended Cab (76.5in. Bed)			
	2.5,3 in. Cat-Back	A		15809
	2.5 in. Cat-Back	F		15820
	2.5 in. Cat-Back	C		16864
2000-2003	V8 4.7L; Extended Cab (76.5in. Bed)			
	2.5,3 in. Cat-Back	A		15809
	2.5 in. Cat-Back	F		15820
	2.5 in. Cat-Back	C		16864

EXIT STYLE CONFIGURATIONS:

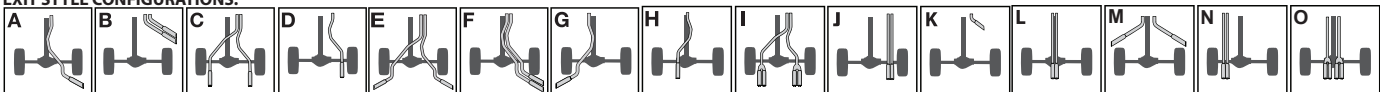

SOME DUAL SYSTEMS ON OPTIONS "C" MAY NEED MODIFICATION TO FIT AROUND TRAILER HITCHES

MAGNAFLOW

Exhaust
PRODUCTS



QUALITY. POWER. SOUND.

MagnaFlow's Race Series mufflers are designed for the maximum performance of full race or street/strip vehicles. With many racing venues imposing strict DB level requirements for racers, MagnaFlow's straight through design Race Series mufflers reduce DB levels on high power vehicles without any performance loss. The Race Series features stainless steel construction for maximum longevity, durability and power. Visit us online to hear your system, check out dyno results, up to date applications and more.

★ A M E R I C A N ★
MUSCLE™

- Lifetime Warranty
- 100% Stainless Steel
- 2.5" and 3" Dual Kits
- Cat-Back systems available for most new American Muscle, including Challenger, Charger, Corvette, Magnum and Mustang
- Proudly made in the USA



• www.MagnaFlow.com •

• 800.990.0905 •



3.5" x 7" Oval Body Mufflers

11" Offset/Offset

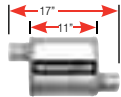

IN/OUT	STAINLESS
2"/2.25"	11132

14" Center/Center

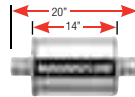

IN/OUT	STAINLESS
1.75"	11113
2"	11114

14" Center/Offset

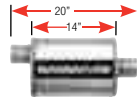

IN/OUT	STAINLESS
1.75"	11123
2"	11124

14" Offset/Offset

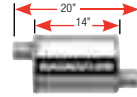

IN/OUT	STAINLESS
1.75"	11133
2"	11134

14" Single/Dual

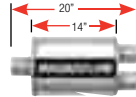

SINGLE/DUAL	STAINLESS
2.25"/2" Dual	11148

4" x 9" Oval Body Mufflers

11" Center/Offset

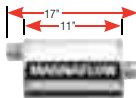

IN/OUT	STAINLESS	POLISH-SS
2.25"	11365	14362
2.5"	11366	14363

11" Dual/Dual

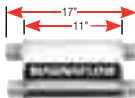

IN/OUT	STAINLESS	POLISH-SS
2.25"	11378	14378
2.5"	11379	14379

11" Offset/Offset Same Side

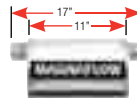

IN/OUT	STAINLESS	POLISH-SS
2.25" Same Side	11375	14375
2.5" Same Side	11376	14376

14" Center/Center

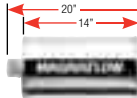

IN/OUT	STAINLESS	POLISH-SS
2"	11214	N/A
2.25"	11215	14315
2.5"	11216	14316
3"	11219	14319

14" Center/Offset

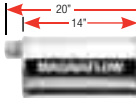

IN/OUT	STAINLESS	POLISH-SS
2"	11224	14324
2.25"	11225	14325
2.5"	11226	14326
3"	11229	14329

14" Offset/Offset

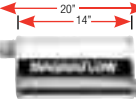

IN/OUT	STAINLESS	POLISH-SS
2"	11234	N/A
2.25"	11235	14335
2.5"	11236	14336

14" Dual/Dual

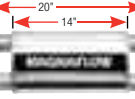

IN/OUT	STAINLESS	POLISH-SS
2.25"	11385*	14385*
2.5"	11386*	14386*

* Tru-X Perforated Core

14" Offset/Offset Same Side

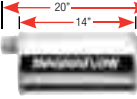

IN/OUT	POLISHED S.S.
2.5"	14377

18" Center/Center

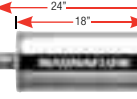

IN/OUT	STAINLESS	POLISH-SS
2"	11244	N/A
2.25"	11245	N/A
2.5"	11246	N/A
3"	11249	N/A

18" Center/Offset

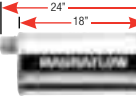

IN/OUT	STAINLESS	POLISH-SS
2"	11254	N/A
2.25"	11255	14355
2.5"	11256	14356
3"	11259	14359

18" Offset/Offset

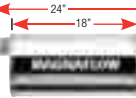

IN/OUT	STAINLESS	POLISH-SS
2"	11264	N/A
2.25"	11265	14365
2.5"	11266	14366

5" x 8" Oval Body Mufflers

6" Center/Center

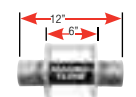

IN/OUT	STAINLESS	POLISH-SS
2.5"	N/A	14148
3"	N/A	14149
3.5"	N/A	14150
4"	N/A	14152

14" Center/Center

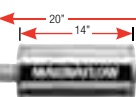

IN/OUT	STAINLESS	POLISH-SS
3.5"	N/A	14151
4"	N/A	14153
2"	12214	14214
2.25"	12215	14215
2.5"	12216	14216
3"	12219	14219

14" Center/Offset

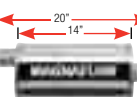

IN/OUT	STAINLESS	POLISH-SS
2"	12224	N/A
2.25"	12225	14225
2.5"	12226	14226
3"	12229	14229

14" Offset/Offset

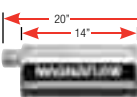

IN/OUT	POLISHED S.S.
2.25"	14235
2.5"	14236
3"	14239

14" Offset/Offset Same Side

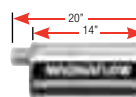

IN/OUT SAME SIDE	POLISH-SS
2.5" Same Side	14211

5" x 8" Oval Body Mufflers (cont.)

14" Offset/Offset Same End



IN/OUT SAME SIDE	POLISH-SS
2.5" Same End	14210

14" Single/Dual

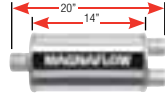

SINGLE/DUAL	STAINLESS	POLISH-SS
2" Dual	12128	14222
2.25" Dual	12148	14220
2.25" Dual	12138	14223
2.5" Dual	12158	14218
3" Dual	12198	14221

18" Center/Center

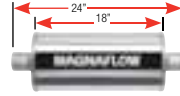

IN/OUT	STAINLESS	POLISH-SS
2"	12244	N/A
2.25"	12245	14245
2.5"	12246	14246
3"	12249	14249

18" Offset/Offset

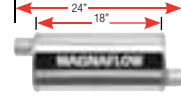

IN/OUT	POLISHED S.S.
2.25"	14262
2.5"	14263
3"	14264

18" Center/Offset

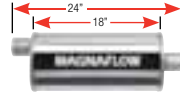

IN/OUT	STAINLESS	POLISH-SS
2"	12254	N/A
2.25"	12255	14255
2.5"	12256	14256
3"	12259	14259

18" Single/Dual

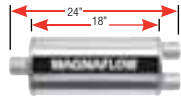

SINGLE/DUAL	STAINLESS	POLISH-SS
2.25"/2.25"	12251	N/A
2.5"/2"	12280	N/A
2.5"/2.25"	12258	14258
2.5"/2.5"	12268	N/A
3"/2.25"	12278	14278
3"/2.5"	12288	14288
3"/3"	12298	14298

18" Dual/Dual

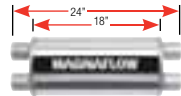

DUAL/DUAL	STAINLESS	POLISH-SS
2.5"/2.5"	12468*	14468*
3"/3"	12469	N/A

* Tru-X Perforated Core

24" Center/Center

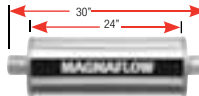

IN/OUT	STAINLESS
2.5"	12276
3"	12279

24" Center/Offset

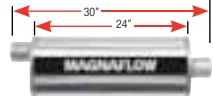

IN/OUT	STAINLESS	POLISH-SS
2.5"	12286	14250
3"	12289	14251

24" Offset/Offset

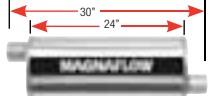

IN/OUT	POLISHED S.S.
2.5"	14260
3"	14261

24" Single/Dual

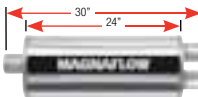

SINGLE/DUAL	STAINLESS
2.5"/2.5" Dual	12368
3"/2.5" Dual	12388
3"/3" Dual	12398

Camaro/Firebird

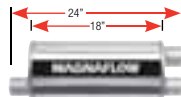

SINGLE/DUAL	STAINLESS	POLISH-SS
2.5"/2.25" Dual	12266	14266
2.5"/2.5" Dual	12265	N/A
3"/2.5" Dual	12267	14267

(Camaro mufflers are not reversible.)

V6 Camaro

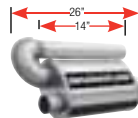

IN/OUT	POLISHED S.S.
2.5"/2.5" Dual	14277

(Camaro mufflers are not reversible.)



5" x 11" Oval Body Mufflers

22" Center/Center

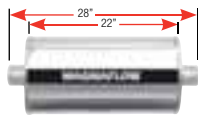

IN/OUT	STAINLESS	POLISH-SS
2.5"	12576	14576
3"	12579	14579

22" Center/Offset



IN/OUT	STAINLESS	POLISH-SS
2.5"	12586	14586
3"	12589	14589
3.5"	12909	14909

22" Offset/Offset

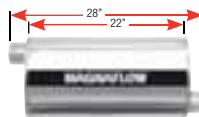

IN/OUT	STAINLESS	POLISH-SS
2.5"	12577	14577
3"	12578	14578

22" Single/Dual

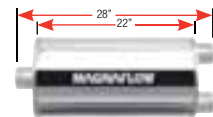

SINGLE/DUAL	STAINLESS	POLISH-SS
2.5"/2.25"	12580	14580
3"/2.5"	12588	14588
3"/3"	12590	14590
3.5"/2.5"	12587	14587
4"/3"	12594	14594
3.5"/3"	12595	14595

22" Dual/Dual

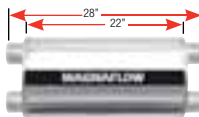

DUAL/DUAL	STAINLESS	POLISH-SS
2.5"/2.5"	12568*	14568*
3"/2.5"	12569*	N/A
3"/3"	12599*	N/A

* Tru-X Perforated Core

4" Round Body Mufflers

14" Center/Center

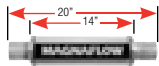

IN/OUT	CORE	STAINLESS	POLISH-SS
2"	2.5"	10414	14414
2.25"	2.5"	10415	14415
2.5"	2.5"	10416	14416
3"	3"	N/A	14419
2"	2"	10444	14444
2.25"	2"	10445	14445

18" Center/Center

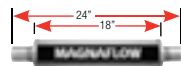

IN/OUT	STAINLESS	POLISH-SS
2"	10424	N/A
2.25"	10425	N/A
2.5"	10426	N/A

22" Center/Center

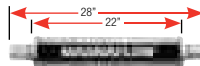

IN/OUT	STAINLESS	POLISH-SS
2"	10434	N/A
2.25"	10435	N/A
2.5"	10436	N/A

5" Round Body Mufflers

14" Center/Center



IN/OUT	STAINLESS	POLISH-SS
2.25"	12865	14865
2.5"	12866	14866
3"	12867	14867

6" Round Body Mufflers

6" Center/Center

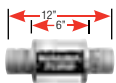

IN/OUT	STAINLESS	POLISH-SS
2.5"	N/A	14158
3"	N/A	14159
3.5"	N/A	14160
4"	N/A	14162

14" Center/Center

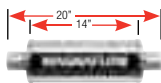

IN/OUT	STAINLESS	POLISH-SS
3.5"	N/A	14161
4"	N/A	14163
2"	12614	14614
2.25"	12615	14615
2.5"	12616	14616
3"	12619	14619

14" Offset/Offset

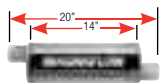

IN/OUT	STAINLESS	POLISH-SS
2"	12634	N/A
2.25"	12635	N/A
2.5"	12636	N/A

18" Center/Center

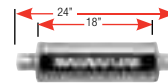

IN/OUT	STAINLESS	POLISH-SS
2"	12644	N/A
2.25"	12645	N/A
2.5"	12646	N/A
3"	12649	N/A

27" Center/Center

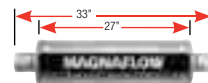

IN/OUT	STAINLESS	POLISH-SS
2.5"	12640	N/A

30" Center/Center

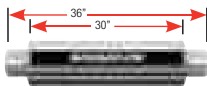

IN/OUT	STAINLESS	POLISH-SS
3"	12641	14641

7" Round Body Mufflers

14" Center/Center

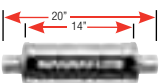

IN/OUT	STAINLESS	POLISH-SS
2"	N/A	14714
2.25"	N/A	14715
2.5"	N/A	14716
3"	N/A	14719

24" Single/Dual

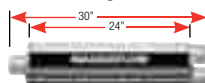

SINGLE/DUAL	STAINLESS
3"/2.5" Dual	12763

27" Single/Dual

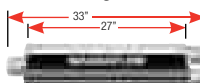

SINGLE/DUAL	STAINLESS
2.5"/2.25" Dual	12761

30" Single/Dual

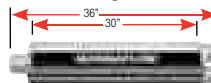

SINGLE/DUAL	STAINLESS
3"/2.5" Dual	12762

7" Round Body Diesel Mufflers

14" Diesel Center/Center

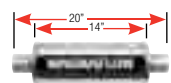

IN/OUT	STAINLESS	POLISH-SS
4"	12770	14770

20" Diesel Center/Center

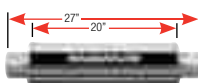

IN/OUT	STAINLESS	POLISH-SS
4"	12771	14771

24" Diesel Center/Center

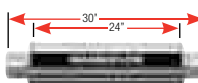

IN/OUT	STAINLESS	POLISH-SS
4"	12772	14772

30" Diesel Center/Center

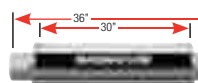

IN/OUT	STAINLESS	POLISH-SS
4"	12773	14773

24" Diesel Center/Center

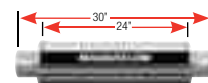

IN/OUT	STAINLESS	POLISH-SS
5"	12774	14774

Race /Specialty Mufflers

Now that racetracks are enforcing stricter decibel level restrictions, MagnaFlow is giving the consumer another option when it comes to choosing a muffler to stay within those guidelines.

MagnaFlow's specialty mufflers feature stainless steel bodies, end caps and perforated cores. With our straight through, Wide Open Performance design, our mufflers give you that true MagnaFlow performance while meeting all track decibel level requirements.

4" ROUND RACE SERIES MUFFLERS



6" Center/Center

IN/OUT	LENGTH	OVERALL	PART #
2.5"	6"	12"	14156

5" x 8" OVAL RACE SERIES MUFFLERS



6" Center/Center

IN/OUT	LENGTH	OVERALL	PART #
2.5"	6"	12"	14148
3"	6"	12"	14149
3.5"	6"	12"	14150
4"	6"	12"	14152

6" ROUND RACE SERIES MUFFLERS



6" Center/Center

IN/OUT	LENGTH	OVERALL	PART #
2.5"	6"	12"	14158
3"	6"	12"	14159
3.5"	6"	12"	14160
4"	6"	12"	14162



14" Center/Center

IN/OUT	LENGTH	OVERALL	PART #
3.5"	14"	20"	14151
4"	14"	20"	14153



14" Center/Center

IN/OUT	LENGTH	OVERALL	PART #
3.5"	14"	20"	14161
4"	14"	20"	14163



GlassPack Mufflers

MagnaFlow GlassPack Mufflers are designed for increased performance with an aluminized steel body, perforated core, straight through design and precision robotic CNC-welding. Our non-fiberglass acoustic packing material delivers the classic GlassPack sound that you are looking for without sound degradation or blowout. MagnaFlow GlassPack Mufflers are proudly made in the USA.

To determine which muffler works for you, consider the following:

- Inlet/Outlet diameter
- Overall size of muffler being replaced
- Amount of space available for muffler
- Sound – small muffler means big sound

SMALL



Part # 18124

IN/OUT	LENGTH	OVERALL DIAMETER
2"	18"	22" 3.5"

Part # 18125

IN/OUT	LENGTH	OVERALL DIAMETER
2.25"	18"	22" 3.5"

Part # 18129

IN/OUT	LENGTH	OVERALL DIAMETER
3"	18"	22" 4"

MEDIUM



Part # 18134

IN/OUT	LENGTH	OVERALL DIAMETER
2"	22"	26" 3.5"

Part # 18135

IN/OUT	LENGTH	OVERALL DIAMETER
2.25"	22"	26" 3.5"

LARGE



Part # 18144

IN/OUT	LENGTH	OVERALL DIAMETER
2"	26"	30" 3.5"

Part # 18145

IN/OUT	LENGTH	OVERALL DIAMETER
2.25"	26"	30" 3.5"

Part # 18146

IN/OUT	LENGTH	OVERALL DIAMETER
2.5"	26"	30" 4"

GLASSPACK FEATURES

- Proudly Made in the USA
- Flow-bench tested, dyno proven
- Designed for maximum performance
- Anti-corrosive aluminized construction
- Deep exhaust note that demands attention
- High Temperature acoustic packing material
- Sound of horsepower from idle to open throttle
- Perforated core for straight-through performance design



Part # 02237
Display Only

Part # 02238
With GlassPacks

Universal Mufflers with Tips

STREET SERIES — Feature a high-flow tuning tube for street machines with bolt-on performance modifications and custom body kits.

RACE SERIES — Feature large diameter internal core for aggressive race car sound with maximum rpm pulling power. Recommended for turbo, nitrous and wild cam applications.

5" x 8" Oval Body Mufflers



4" Round Body Mufflers



5" Round Body Mufflers

14852 STREET
 4" Diameter Tip
 Single Wall
 Straight
 3.5" Length
 2.25" Inlet
 Removable Sound Damper*



14857 STREET
 4" Diameter Tip
 Single Wall
 Straight
 3.5" Length
 2.25" Inlet



14854 STREET
 4" Diameter Tip
 Single Wall
 Angle Cut
 3.5" Length
 2.25" Inlet
 Removable Sound Damper*



14859 STREET
 4" Diameter Tip
 Single Wall
 Angle Cut
 3.5" Length
 2.25" Inlet



14853 STREET
 4" Diameter Tip
 Single Wall
 Straight
 1.75" Length
 2.25" Inlet
 Removable Sound Damper*



14856 STREET
 4" Diameter Tip
 Single Wall
 Angle Cut
 1.75" Length
 2.25" Inlet
 Removable Sound Damper*



14855 STREET
 4" Diameter Tip
 Double Wall
 Rolled Angle
 2" Length
 2.25" Inlet



14858 STREET
 4" Diameter Tip
 Single Wall
 Straight
 1.25" Length
 2.25" Inlet



14860 STREET
 4" Diameter Tip
 Single Wall
 Angle Cut
 1.25" Length
 2.25" Inlet



6" Round Body Mufflers

14811 STREET
 4" Diameter Tip
 Cone Rolled Edge
 1.25" Length
 2.25" Inlet
 14" Muffler Length



14822 STREET
 4" Diameter Tip
 Single Wall, Straight Cut
 3" Length, 2.25" Inlet
 14" Muffler Length
14843 RACE
 2.25" Inlet - 2.5" Internal Race Core



14823 STREET
 4" Diameter Tip
 Single Wall, Angle Cut
 3.5" Length
 2.25" Inlet
 14" Muffler Length



14813 STREET
 4" Diameter Tip
 Double Wall, Angle Cut
 4" Length
 2.25" Inlet
 14" Muffler Length



14864 STREET
 3" x 4.5" Diameter Tip
 Double Wall, Oval
 Angle Cut
 6.25" Length
 2.25" Inlet



14821 STREET
 4" Diameter Tip
 Single Wall, Angle Cut
 5" Length, 2.25" Inlet
 14" Muffler Length
14842 RACE
 2.25" Inlet - 2.5" Internal Race Core



14820 STREET
 4" Diameter Tip
 Single Wall
 Straight Cut
 3.5" Length
 2.25" Inlet
 14" Muffler Length



14846 STREET
 4" Diameter Tip
 Single Wall, Straight Cut
 1.25" Length, 2.25" Inlet
 14" Muffler Length
14848 RACE
 2.25" Inlet - 2.5" Internal Race Core



14817 STREET
 4" Diameter Tip
 Double Wall, Straight Cut
 4" Length, 2.25" Inlet
 14" Muffler Length
14840 RACE
 2.25" Inlet - 2.5" Internal Race Core



14847 STREET
 4" Diameter Tip
 Single Wall, Angle Cut
 1.25" Length, 2.25" Inlet
 14" Muffler Length
14849 RACE
 2.25" Inlet - 2.5" Internal Race Core



7" Round Body Mufflers

14836 STREET
 4.5" Diameter Round Tip
 Double Wall, Domed,
 Tanabe Angle Cut
 6.5" Length, 2.25" Inlet
14845 RACE
 2.25" Inlet - 2.5" Internal Race Core



14812 STREET
 4" Diameter Tip
 Double Wall, Straight
 4" Length
 2.25" Inlet



14806 RACE
 4" Diameter Tip
 Double Wall, Angle Cut
 3.5" Length
 3" Inlet



14826 STREET
 4" Diameter Tip
 Double Wall, Angle Cut
 7" Length
 2.25" Inlet



14824 STREET
 4" Diameter Tip
 Single Wall, Angle Cut
 6" Length
 2.25" Inlet



14825 STREET
 4" Diameter Tip
 Double Wall, Straight Cut
 7" Length
 2.25" Inlet



MAGNAFLOW

Exhaust
PRODUCTS



QUALITY. POWER. SOUND.

At MagnaFlow Exhaust Products, we pride ourselves on the durability and quality of our products. Whether it's a cat-back system for your American Muscle Car or the parts you need to fabricate a custom exhaust, MagnaFlow has what you're looking for. With nearly 30 years of producing high quality products, our exhaust systems not only perform, but they also sound great from the track to your daily commute. Visit us online to see our complete product line plus hear your American Muscle exhaust sound clips.

★ A M E R I C A N ★
MUSCLE™

- Lifetime Warranty
- 100% Stainless Steel
- 2.5" and 3" Dual Kits
- Systems available for most A-, E-, F- and X-Body classics
- Cat-Back systems available for most new American Muscle, including Challenger, Charger, Corvette, Magnum and Mustang
- Proudly made in the USA



• [www. MagnaFlow.com](http://www.MagnaFlow.com) •



• 800.990.0905 •

True Clamp-On Tips for Trucks & SUV's

These universal tips feature the beefiest clamp in the business. The clamp is welded to the tip, uses high strength weather-proof hardware, and has a full 4" inch range adjustment. Best of all, 3 part numbers cover more than 98% of all truck and SUV applications. Additional applications are provided for smaller vehicles, including some muscle car and tuner applications.

FITS 4" TAIL PIPE



FITS 3.5" TAIL PIPE



FITS 2.75" TO 3" TAIL PIPE



FITS 2.5" TO 2.75" TAIL PIPE



FITS 2.25" TO 2.5" TAIL PIPE



FITS 2.75" TO 3" TAIL PIPE



FITS 2.5" TO 2.75" TAIL PIPE



Stainless Steel Tips – T-304

ROLLED - OBLONG - DTM

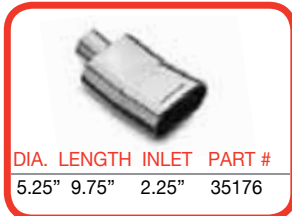

ROLLED - OBLONG - ANGLE



ROLLED - SQUARE - STRAIGHT

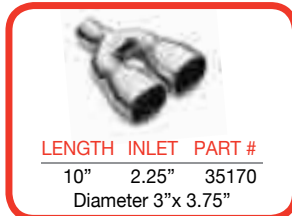

ROLLED - OVAL - STRAIGHT

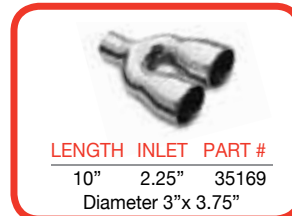

ROLLED - ROUND

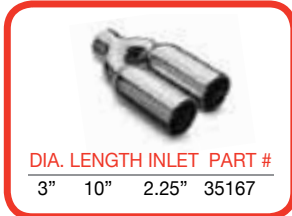

ROLLED - ROUND - ANGLE CUT



ROLLED - DUAL - DTM





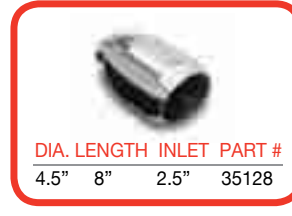



TANABE - ROUND









Stainless Steel Tips – Large Diameter

<p>15° ROLLED EDGE</p>  <p>DIA. LENGTH INLET PART #</p> <table border="1"> <tr><td>3"</td><td>12"</td><td>2.5" I.D.</td><td>35204</td></tr> <tr><td>3"</td><td>12"</td><td>3" O.D.</td><td>35110</td></tr> <tr><td>3"</td><td>18"</td><td>2.5" I.D.</td><td>35111</td></tr> <tr><td>3"</td><td>22"</td><td>2.5" I.D.</td><td>35112</td></tr> <tr><td>3.5"</td><td>12"</td><td>3" I.D.</td><td>35113</td></tr> <tr><td>3.5"</td><td>18"</td><td>2.5" I.D.</td><td>35217</td></tr> <tr><td>3.5"</td><td>18"</td><td>2.5" I.D.</td><td>35114</td></tr> <tr><td>3.5"</td><td>22"</td><td>2.5" I.D.</td><td>35115</td></tr> <tr><td>4"</td><td>12"</td><td>3" I.D.</td><td>35116</td></tr> <tr><td>4"</td><td>18"</td><td>2.5" I.D.</td><td>35117</td></tr> <tr><td>4"</td><td>22"</td><td>2.5" I.D.</td><td>35119</td></tr> </table>	3"	12"	2.5" I.D.	35204	3"	12"	3" O.D.	35110	3"	18"	2.5" I.D.	35111	3"	22"	2.5" I.D.	35112	3.5"	12"	3" I.D.	35113	3.5"	18"	2.5" I.D.	35217	3.5"	18"	2.5" I.D.	35114	3.5"	22"	2.5" I.D.	35115	4"	12"	3" I.D.	35116	4"	18"	2.5" I.D.	35117	4"	22"	2.5" I.D.	35119	<p>15° SLASH CUT</p>  <p>DIA. LENGTH INLET PART #</p> <table border="1"> <tr><td>3"</td><td>12"</td><td>3" O.D.</td><td>35101</td></tr> <tr><td>3"</td><td>18"</td><td>2.5" I.D.</td><td>35102</td></tr> <tr><td>3"</td><td>22"</td><td>2.5" I.D.</td><td>35103</td></tr> <tr><td>3.5"</td><td>12"</td><td>2.5" I.D.</td><td>35205</td></tr> <tr><td>3.5"</td><td>12"</td><td>3" I.D.</td><td>35104</td></tr> <tr><td>3.5"</td><td>18"</td><td>2.5" I.D.</td><td>35105</td></tr> <tr><td>3.5"</td><td>22"</td><td>2.5" I.D.</td><td>35106</td></tr> <tr><td>4"</td><td>12"</td><td>3" I.D.</td><td>35107</td></tr> <tr><td>4"</td><td>18"</td><td>2.5" I.D.</td><td>35108</td></tr> <tr><td>4"</td><td>22"</td><td>2.5" I.D.</td><td>35109</td></tr> </table>	3"	12"	3" O.D.	35101	3"	18"	2.5" I.D.	35102	3"	22"	2.5" I.D.	35103	3.5"	12"	2.5" I.D.	35205	3.5"	12"	3" I.D.	35104	3.5"	18"	2.5" I.D.	35105	3.5"	22"	2.5" I.D.	35106	4"	12"	3" I.D.	35107	4"	18"	2.5" I.D.	35108	4"	22"	2.5" I.D.	35109	<p>45° SLASH CUT</p>  <p>DIA. LENGTH INLET PART #</p> <table border="1"> <tr><td>3"</td><td>18"</td><td>2.25" I.D.</td><td>35140</td></tr> <tr><td>3"</td><td>18"</td><td>2.5" I.D.</td><td>35138</td></tr> <tr><td>3"</td><td>22"</td><td>2.25" I.D.</td><td>35141</td></tr> <tr><td>3"</td><td>22"</td><td>2.5" I.D.</td><td>35139</td></tr> <tr><td>3.5"</td><td>18"</td><td>2.25" I.D.</td><td>35216</td></tr> <tr><td>3.5"</td><td>18"</td><td>2.5" I.D.</td><td>35143</td></tr> <tr><td>3.5"</td><td>22"</td><td>2.5" I.D.</td><td>35144</td></tr> <tr><td>4"</td><td>18"</td><td>2.5" I.D.</td><td>35146</td></tr> <tr><td>4"</td><td>22"</td><td>2.5" I.D.</td><td>35147</td></tr> </table>	3"	18"	2.25" I.D.	35140	3"	18"	2.5" I.D.	35138	3"	22"	2.25" I.D.	35141	3"	22"	2.5" I.D.	35139	3.5"	18"	2.25" I.D.	35216	3.5"	18"	2.5" I.D.	35143	3.5"	22"	2.5" I.D.	35144	4"	18"	2.5" I.D.	35146	4"	22"	2.5" I.D.	35147	<p>RESONATED</p>  <p>35173</p> <p>Rolled - Round - Angle Cut 4" Round x 12" Long x 2.25" I.D.</p> <p>35174</p> <p>Rolled - Oval - Angle Cut 3.5"x 4.25" Oval x 12" Long x 2.25" I.D.</p>	<p>DOUBLE WALL</p>  <p>35172</p> <p>Dual - Rolled - Oval - Straight 3.5-x 5.5-Oval x 14- Long x 3- I.D.</p> <p>35171</p> <p>Rolled - Oval - Angle Cut 3.25-x 4.75-Oval x 8.25- Long x 3- I.D.</p>	<p>8" RADIUS</p>  <p>35182</p> <p>Round - Straight Cut 4" Round x 18" Long x 3" I.D.</p> <p>35183</p> <p>Round - Straight Cut 5" Round x 18" Long x 4" I.D.</p>
3"	12"	2.5" I.D.	35204																																																																																																																										
3"	12"	3" O.D.	35110																																																																																																																										
3"	18"	2.5" I.D.	35111																																																																																																																										
3"	22"	2.5" I.D.	35112																																																																																																																										
3.5"	12"	3" I.D.	35113																																																																																																																										
3.5"	18"	2.5" I.D.	35217																																																																																																																										
3.5"	18"	2.5" I.D.	35114																																																																																																																										
3.5"	22"	2.5" I.D.	35115																																																																																																																										
4"	12"	3" I.D.	35116																																																																																																																										
4"	18"	2.5" I.D.	35117																																																																																																																										
4"	22"	2.5" I.D.	35119																																																																																																																										
3"	12"	3" O.D.	35101																																																																																																																										
3"	18"	2.5" I.D.	35102																																																																																																																										
3"	22"	2.5" I.D.	35103																																																																																																																										
3.5"	12"	2.5" I.D.	35205																																																																																																																										
3.5"	12"	3" I.D.	35104																																																																																																																										
3.5"	18"	2.5" I.D.	35105																																																																																																																										
3.5"	22"	2.5" I.D.	35106																																																																																																																										
4"	12"	3" I.D.	35107																																																																																																																										
4"	18"	2.5" I.D.	35108																																																																																																																										
4"	22"	2.5" I.D.	35109																																																																																																																										
3"	18"	2.25" I.D.	35140																																																																																																																										
3"	18"	2.5" I.D.	35138																																																																																																																										
3"	22"	2.25" I.D.	35141																																																																																																																										
3"	22"	2.5" I.D.	35139																																																																																																																										
3.5"	18"	2.25" I.D.	35216																																																																																																																										
3.5"	18"	2.5" I.D.	35143																																																																																																																										
3.5"	22"	2.5" I.D.	35144																																																																																																																										
4"	18"	2.5" I.D.	35146																																																																																																																										
4"	22"	2.5" I.D.	35147																																																																																																																										
<p>TURNDOWN</p>  <p>DIA. LENGTH INLET PART #</p> <table border="1"> <tr><td>2.5"</td><td>13"</td><td>2.75" I.D.</td><td>35179</td></tr> <tr><td>3"</td><td>13"</td><td>3" I.D.</td><td>35180</td></tr> <tr><td>3.5"</td><td>16"</td><td>3.5" I.D.</td><td>35178</td></tr> <tr><td>4"</td><td>16"</td><td>4" I.D.</td><td>35181</td></tr> <tr><td>5"</td><td>20"</td><td>4" I.D.</td><td>35188</td></tr> </table>	2.5"	13"	2.75" I.D.	35179	3"	13"	3" I.D.	35180	3.5"	16"	3.5" I.D.	35178	4"	16"	4" I.D.	35181	5"	20"	4" I.D.	35188	<p>DIESEL - 15° ROLLED EDGE</p>  <p>DIA. LENGTH INLET PART #</p> <table border="1"> <tr><td>5"</td><td>8"</td><td>4" I.D.</td><td>35148</td></tr> <tr><td>5"</td><td>13"</td><td>4" I.D.</td><td>35120</td></tr> <tr><td>5"</td><td>24"</td><td>4" I.D.</td><td>35149</td></tr> <tr><td>6"</td><td>13"</td><td>5" I.D.</td><td>35185</td></tr> </table>	5"	8"	4" I.D.	35148	5"	13"	4" I.D.	35120	5"	24"	4" I.D.	35149	6"	13"	5" I.D.	35185	<p>CAMARO - DUAL 2 PER KIT</p>  <p>DIA. LENGTH INLET PART #</p> <table border="1"> <tr><td>2"</td><td>8"</td><td>11"</td><td>2.25" I.D.</td><td>35150</td></tr> </table>	2"	8"	11"	2.25" I.D.	35150	<p>CLAMP-ON 5" DIESEL 15° ROLLED EDGE</p>  <p>DIA. LENGTH INLET PART #</p> <table border="1"> <tr><td>5"</td><td>13"</td><td>4" I.D.</td><td>35184</td></tr> </table>	5"	13"	4" I.D.	35184	<p>CLAMP-ON 5" DIESEL TURNDOWN</p>  <p>DIA. LENGTH INLET PART #</p> <table border="1"> <tr><td>5"</td><td>20"</td><td>4" I.D.</td><td>35187</td></tr> </table>	5"	20"	4" I.D.	35187																																																																								
2.5"	13"	2.75" I.D.	35179																																																																																																																										
3"	13"	3" I.D.	35180																																																																																																																										
3.5"	16"	3.5" I.D.	35178																																																																																																																										
4"	16"	4" I.D.	35181																																																																																																																										
5"	20"	4" I.D.	35188																																																																																																																										
5"	8"	4" I.D.	35148																																																																																																																										
5"	13"	4" I.D.	35120																																																																																																																										
5"	24"	4" I.D.	35149																																																																																																																										
6"	13"	5" I.D.	35185																																																																																																																										
2"	8"	11"	2.25" I.D.	35150																																																																																																																									
5"	13"	4" I.D.	35184																																																																																																																										
5"	20"	4" I.D.	35187																																																																																																																										
<p>CLAMP-ON 5" DIESEL DOUBLE WALL</p>  <p>DIA. LENGTH INLET PART #</p> <table border="1"> <tr><td>5"</td><td>13"</td><td>4" I.D.</td><td>35186</td></tr> </table>	5"	13"	4" I.D.	35186	<p>30° SLASH CUT DOUBLE WALL</p>  <p>DIA. LENGTH INLET PART #</p> <table border="1"> <tr><td>3.5"</td><td>9.5"</td><td>3" I.D.</td><td>35206</td></tr> </table>	3.5"	9.5"	3" I.D.	35206	<p>15° ROLLED DOUBLE WALL</p>  <p>DIA. LENGTH INLET PART #</p> <table border="1"> <tr><td>3.5"</td><td>10"</td><td>2.5" I.D.</td><td>35190</td></tr> </table>	3.5"	10"	2.5" I.D.	35190																																																																																																															
5"	13"	4" I.D.	35186																																																																																																																										
3.5"	9.5"	3" I.D.	35206																																																																																																																										
3.5"	10"	2.5" I.D.	35190																																																																																																																										

Stainless Steel Tips – Single Wall

<p>ROUND - STRAIGHT</p>  <p>DIA. LENGTH INLET PART #</p> <table border="1"> <tr><td>3"</td><td>7.5"</td><td>2.25"</td><td>35122</td></tr> <tr><td>3.5"</td><td>7.5"</td><td>2.25"</td><td>35123</td></tr> <tr><td>4"</td><td>4.5"</td><td>2.25"</td><td>35124</td></tr> <tr><td>3.5"</td><td>4.5"</td><td>2.25"</td><td>35125</td></tr> <tr><td>4"</td><td>7.5"</td><td>2.25"</td><td>35126</td></tr> </table>	3"	7.5"	2.25"	35122	3.5"	7.5"	2.25"	35123	4"	4.5"	2.25"	35124	3.5"	4.5"	2.25"	35125	4"	7.5"	2.25"	35126	<p>ROUND - ANGLE CUT</p>  <p>DIA. LENGTH INLET PART #</p> <table border="1"> <tr><td>4"</td><td>7"</td><td>2.25"</td><td>35121</td></tr> <tr><td>4"</td><td>4.5"</td><td>2.25"</td><td>35127</td></tr> </table>	4"	7"	2.25"	35121	4"	4.5"	2.25"	35127	<p>ROLLED - ROUND - ANGLE CUT</p>  <p>DIA. LENGTH INLET PART #</p> <table border="1"> <tr><td>3"</td><td>6.75"</td><td>2.25"</td><td>35163</td></tr> <tr><td>4"</td><td>8.25"</td><td>2.25"</td><td>35164</td></tr> <tr><td>4"</td><td>6.25"</td><td>2.25"</td><td>35177</td></tr> </table>	3"	6.75"	2.25"	35163	4"	8.25"	2.25"	35164	4"	6.25"	2.25"	35177	<p>ROLLED - OVAL - ANGLE CUT</p>  <p>LENGTH INLET PART #</p> <table border="1"> <tr><td>7.25"</td><td>2.25"</td><td>35159</td></tr> </table> <p>Diameter 3"x 3.75"</p>	7.25"	2.25"	35159	<p>ROLLED - OVAL - ANGLE CUT</p>  <p>LENGTH INLET PART #</p> <table border="1"> <tr><td>7"</td><td>2.25"</td><td>35158</td></tr> </table> <p>Diameter 3.25"x 4.5"</p>	7"	2.25"	35158	<p>ROLLED - SQUARE</p>  <p>LENGTH INLET PART #</p> <table border="1"> <tr><td>7.25"</td><td>2.25"</td><td>35157</td></tr> </table> <p>Diameter 3"x 3.5"</p>	7.25"	2.25"	35157
3"	7.5"	2.25"	35122																																																			
3.5"	7.5"	2.25"	35123																																																			
4"	4.5"	2.25"	35124																																																			
3.5"	4.5"	2.25"	35125																																																			
4"	7.5"	2.25"	35126																																																			
4"	7"	2.25"	35121																																																			
4"	4.5"	2.25"	35127																																																			
3"	6.75"	2.25"	35163																																																			
4"	8.25"	2.25"	35164																																																			
4"	6.25"	2.25"	35177																																																			
7.25"	2.25"	35159																																																				
7"	2.25"	35158																																																				
7.25"	2.25"	35157																																																				

Stainless Steel Tips – Double Wall

<p>DTM - ROUND</p>  <p>DIA. LENGTH INLET PART #</p> <table border="1"> <tr><td>2.5"</td><td>8.25"</td><td>2.25"</td><td>35130</td></tr> <tr><td>3"</td><td>8.5"</td><td>2.25"</td><td>35133</td></tr> </table>	2.5"	8.25"	2.25"	35130	3"	8.5"	2.25"	35133	<p>DTM - SQUARE</p>  <p>DIA. LENGTH INLET PART #</p> <table border="1"> <tr><td>2.5"</td><td>8.5"</td><td>2.25"</td><td>35132</td></tr> <tr><td>3"</td><td>8.5"</td><td>2.25"</td><td>35135</td></tr> </table>	2.5"	8.5"	2.25"	35132	3"	8.5"	2.25"	35135	<p>ROLLED - ROUND - ANGLE CUT</p>  <p>DIA. LENGTH INLET PART #</p> <table border="1"> <tr><td>3"</td><td>7"</td><td>2.25"</td><td>35131</td></tr> <tr><td>4"</td><td>5"</td><td>2.5"</td><td>35136</td></tr> </table>	3"	7"	2.25"	35131	4"	5"	2.5"	35136	<p>ROLLED - OVAL - ANGLE CUT</p>  <p>LENGTH INLET PART #</p> <table border="1"> <tr><td>7.5"</td><td>2.25"</td><td>35129</td></tr> </table> <p>Diameter 2.5"x 3.2"</p>	7.5"	2.25"	35129	<p>RECTANGLE - ANGLE CUT</p>  <p>LENGTH INLET PART #</p> <table border="1"> <tr><td>7.5"</td><td>2.25"</td><td>35134</td></tr> </table> <p>Diameter 2.5"x 2.7"</p>	7.5"	2.25"	35134	<p>DUAL DTM - ROUND</p>  <p>DIA. LENGTH INLET PART #</p> <table border="1"> <tr><td>3"</td><td>11"</td><td>2.25"</td><td>35166</td></tr> </table>	3"	11"	2.25"	35166
2.5"	8.25"	2.25"	35130																																				
3"	8.5"	2.25"	35133																																				
2.5"	8.5"	2.25"	35132																																				
3"	8.5"	2.25"	35135																																				
3"	7"	2.25"	35131																																				
4"	5"	2.5"	35136																																				
7.5"	2.25"	35129																																					
7.5"	2.25"	35134																																					
3"	11"	2.25"	35166																																				

Hangers & Clamps



DIAMETER	LENGTH	10-PACK PART #
.375" Single	12"	10150
.5" Single	12"	10151



DIAMETER	LENGTH	10-PACK PART #
.375" Single	10"	10152
.5" Single	10"	10153



DIAMETER	10-PACK PART #	DIAMETER	10-PACK PART #
2"	10160	3"	10164
2.25"	10161	3.5"	10165
2.5"	10162	4"	10166
2.75"	10163	5"	10167

Smooth Transitions

90° L-BEND



INLET/OUTLET O.D.	CENTERLINE RADIUS	SINGLE PART #	10-PACK PART #
2.5"	4"	10706	10720
3"	5"	10709	10721

180° J-BEND



INLET/OUTLET O.D.	CENTERLINE RADIUS	SINGLE PART #	10-PACK PART #
2.5"	4"	10716	10722
3"	5"	10719	10723

45° BEND PIPE



INLET/OUTLET O.D.	CENTERLINE RADIUS	SINGLE PART #	10-PACK PART #
2.5"	4"	10736	10724
3"	5"	10739	10725

3-IN-1 PIPE



INLET/OUTLET O.D.	SINGLE PART #	10-PACK PART #
2.5"	10740	10760
3"	10741	10761
3"	10742	10762



Transition Pipes

Y-PIPE TRANSITION



INLET I.D.	OUTLET I.D.	LENGTH	PART #
2.25" Single	2" Dual	10"	10748
2.5" Single	2.25" Dual	10"	10758
2.5" Single	2.5" Dual	10"	10768
3" Single	2.5" Dual	10"	10778
3" Single	3" Dual	10.25"	10798

X-PIPE TRANSITION



INLET I.D.	OUTLET I.D.	LENGTH	PART #
2.25" Dual	2.25" Dual	9.5"	10780
2.5" Dual	2.5" Dual	9.5"	10781
3" Dual	3" Dual	9.5"	10782

X-PIPE TRANSITION



INLET I.D.	OUTLET I.D.	LENGTH	PART #
2.25" Dual	2.25" Dual	12"	10790
2.5" Dual	2.5" Dual	12"	10791
3" Dual	3" Dual	12"	10792

Y-PIPE TRANSITION



INLET I.D.	OUTLET I.D.	LENGTH	PART #
2.5" Dual	2.5" Single	8"	10733
2" Dual	2.5" Single	8"	10735

GIANT 4" Y-PIPE



INLET I.D.	OUTLET I.D.	LENGTH	PART #
4" Dual	3.5" Single	13"	10800
4" Dual	4" Single	13"	10799

H-PIPE TRANSITION



INLET I.D.	OUTLET I.D.	PART #
2.25" Dual	2.25" Dual	10770
2.5" Dual	2.5" Dual	10771

EXHAUST CUT-OUT



INLET I.D.	OUTLET I.D.	LENGTH	PART #
2.25" Dual	2.25" Single	10"	10783
2.5" Dual	2.5" Single	10"	10784
3" Dual	3" Single	10"	10785

UNIVERSAL BALL FLANGES



INLET I.D.	OUTLET I.D.	PART #
2.25" Dual	2.25" Single	10743
2.5" Dual	2.5" Single	10744
3" Dual	3" Single	10745

U-PIPE TRANSITION



IN	OUT	PART #
2.5"	2.5"	10731

90° INLET Y-PIPE



INLET I.D.	OUTLET I.D.	LENGTH	PART #
2.5" Single	2.5" Dual	9"	10732

Y-PIPE TRANSITION



INLET I.D.	OUTLET I.D.	PART #
2.5" Single	2.5" Dual	10734



CHIP FOOSE
 Legendary Car Builder

Custom Builder Kits

Whether you are a professional builder or you are working on your first hot rod or custom car project in a home garage, the Custom Builder Kit includes the MagnaFlow parts you need to get started on a one-off exhaust system. This kit includes all of the basic components needed for your system, including universal hangers, flanges, straight pipes, and mandrel-bent J-, U-, and L-bends.

The MagnaFlow Custom Builder Kits are available in 2.25", 2.5", and 3" diameters and are backed by MagnaFlow's Lifetime Warranty. Be sure to include a set of MagnaFlow performance mufflers to put the finishing touch on your one-of-a-kind exhaust system.



IN/OUT	PART #
2.25" Dual	10701
2.5" Dual	10702
3" Dual	10703



X-Pipe Kits

If you're in the market for a custom exhaust, MagnaFlow's stainless steel X-Pipe kits are a great starting point. Our X-Pipe kits are available in 2.25" dual, 2.5" dual and 3" dual diameters and come complete with an X-Pipe, four pipes and four exhaust band clamps.

Each X-Pipe features a gentler radius, which allows for better exhaust gas scavenging, noise cancellation and better balance between cylinder banks, resulting in a significant increase in power and torque.

*Exhaust cut-out
 sold separately.*

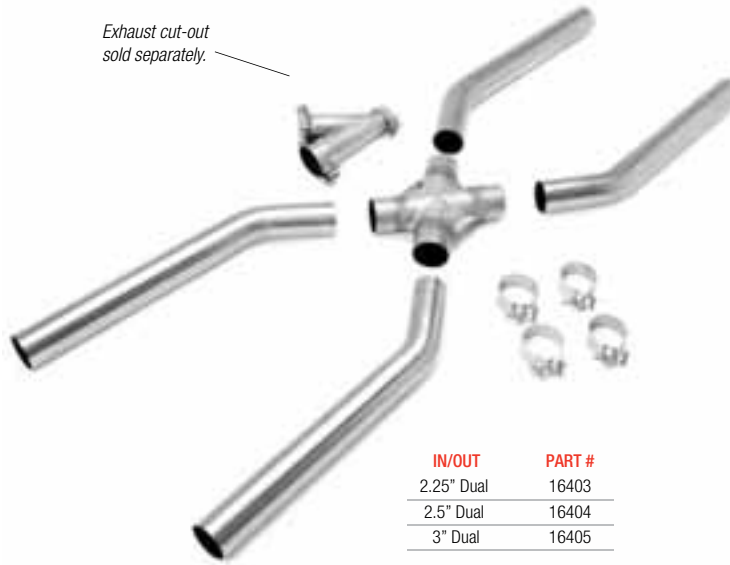

IN/OUT	PART #
2.25" Dual	16403
2.5" Dual	16404
3" Dual	16405



• QUALITY • POWER • SOUND •

MAGNAFLOW

Exhaust
PRODUCTS



LIKE US! JOIN OUR TEAM FOR EXCLUSIVE CONTENT & MORE
FACEBOOK.COM/MAGNAFLOW

NOTES:



MAGNAFLOW *Exhaust* PRODUCTS



GlassPack Mufflers

Performance Exhaust Systems

Universal Catalytic Converters

Exhaust Accessories

Direct-Fit Converters

Universal Mufflers

Universal Spun Body Converters

Direct-Fit Converters

Direct-Fit Manifold Converters

DO IT RIGHT...EVERYTIME.

QUALITY PRODUCTS THAT YOU CAN DEPEND ON

As one of the largest catalytic converter manufacturers in the United States, MagnaFlow has a complete line of universal and direct-fit converters, including specialty designs such as integrated manifold converters for both 49-State and California applications. To complement their full line of OBDI- and OBDII-compliant catalytic converters, MagnaFlow also prides itself on a complete line of stainless steel performance exhaust systems backed by a lifetime warranty. Thirty years of experience and a reputation for manufacturing to the highest quality and performance standards make MagnaFlow the exhaust industry leader.

Mario Andretti
LEGENDARY RACER

Chip Foose
LEGENDARY CAR BUILDER



www.MagnaFlow.com



800-880-0808

MAGNAFLOW

Exhaust
PRODUCTS



QUALITY. POWER. SOUND.

MagnaFlow's Race Series mufflers are designed for the maximum performance of full race or street/strip vehicles. With many racing venues imposing strict DB level requirements for racers, MagnaFlow's straight through design Race Series mufflers reduce DB levels on high power vehicles without any performance loss. The Race Series features stainless steel construction for maximum longevity, durability and power. Visit us online to hear your system, check out dyno results, up to date applications and more.

★ A M E R I C A N ★
MUSCLE™

- Lifetime Warranty
- 100% Stainless Steel
- 2.5" and 3" Dual Kits
- Cat-Back systems available for most new American Muscle, including Challenger, Charger, Corvette, Magnum and Mustang
- Proudly made in the USA



• www.MagnaFlow.com •

• 800.990.0905 •





• QUALITY • POWER • SOUND •

MAGNAFLOW

Exhaust
PRODUCTS



UNIVERSAL CONVERTERS

- 100% stainless steel construction
- OE configuration bodies for optimal fitment
- Proper O2 bung placement and factory capped 90° air tubes (where applicable)



MANIFOLD CONVERTERS

- Stainless steel construction
- OE Fitment and optimized functionality
- On-Board Diagnostics I/II compatible for EPA & CARB
- Engineered to ensure proper engine operation



DIRECT-FIT CONVERTERS

- Stainless Steel Construction with mandrel-bent tubing
- 49-state OBDI & OBDII EPA compliant applications available
- California CARB compliant applications available
- OE fitment utilizing all factory hanger locations and OE flanges for bolt-in installation

